

GCSE Additional Science

21st Century Science

P5 Electric Circuits [Answers]

Name: _____

Important: If at any time you have difficulty with a question in this work booklet, please explain your problem underneath or in the margins of the page with a green pen. Your teacher can then provide you with the help that you need.

Electric Charge

When certain different insulating materials are rubbed against each other they become electrically charged. For example, if we rub a polystyrene rod with a piece of fur, negatively charged electrons are knocked off the fur atoms onto the atoms in the polythene. This makes the polythene negatively electrically charged and the fur positively charged.

Question: What types of object;

[a] Will be attracted to this rod? The rod is _____ so positive objects are attracted.

[b] Will be repelled by this rod? Anything negative.

Materials, which contain extra electrons in this way, are said to possess 'electrostatic charge'. Materials such as glass and polythene are insulators because they will not allow electric charges to pass through them and 'hold' electrostatic charges in this way.

Other examples of producing an electrostatic charge include:

- Rubbing a polythene rod with a duster. It attracts small pieces of paper
- When a balloon is rubbed on a sweater it becomes charged and sticks to the wall
- When a plastic comb is used to comb hair both the comb and hair can become charged.
- Some types of dusting brushes are designed to become charged and attract dust.

Question: Rods of glass, plastic and rubber can be charged by rubbing them with materials such as fur or silk. One way to remember some of these charges is as follows:

Paul Gascoigne Can Score
↑ ↑ ↑ ↑
Positive charge Glass rod or Cellulose acetate rod = rubbing with Silk

Alternatively,

Never eat Poly filler
↑ ↑ ↑ ↙
Negative charge Ebonite rod or Polythene rod = rubbing with Fur

Question: Explain in terms of moving negatively charged particles i.e. electrons how these rods become charged in this way.

Electrons are knocked off the glass / cellulose acetate leaving it with a _____ charge. Electrons are knocked onto the polythene rod leaving it with a _____ charge.

Question: Explain why static charges do not build up on a conductor.

Static negative charges [electrons] are immediately conducted into the metal rod and do not remain static [non-moving] on its surface.

An atom is a small positively charged nucleus surrounded by negatively charged electrons. In a stable, neutral atom, there is the same amount of positive charges (protons) as negative charges (electrons).

Question: (a) If you knock electrons off atoms what charge do they become and why? If you knock electrons onto atoms, what charge do they become and why? If atoms lose electrons [negative], then the atoms will have more positive protons than electrons and so will have a positive charge. If atoms gain electrons, they will have more negative electrons than protons and so have a negative charge.

These rods either positively charged or negatively charged will pick up pieces of paper. The negative charges (electrons) in the paper are attracted to the surface of the paper if a positively charged rod is held close. The paper then is attracted to the rod.

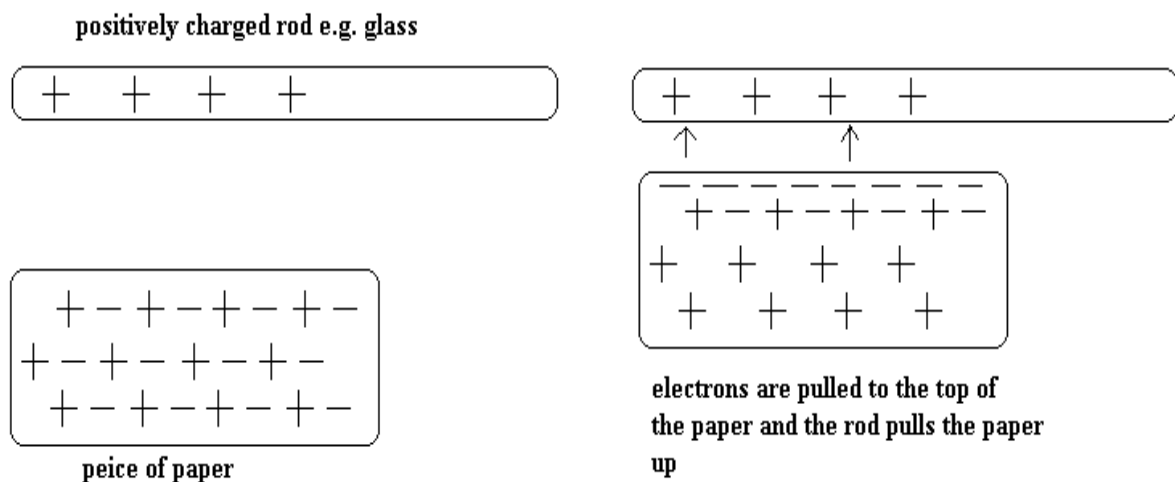

(b) Explain how a negatively charged rod e.g. polythene attracts paper.

The negative rod repels electrons in the paper, to the bottom of the paper. This leaves the positively charged nuclei of the atoms at the top of the paper, which is then attracted to the rod.

(c) Metals are good conductors of electricity because some of the electrons from their atoms can move freely throughout the metal structure. Explain why you could not rub a metal rod with a piece of fur and charge it up like a polythene rod.

The electrons will be conducted into the rod.

(d) Electrostatic charges have many commercial uses. Two important uses are in the spray painting of motorcar bodies and in the removal of dust from chimney gases.

The use of electrostatic charges in spray painting is shown in the diagram below.

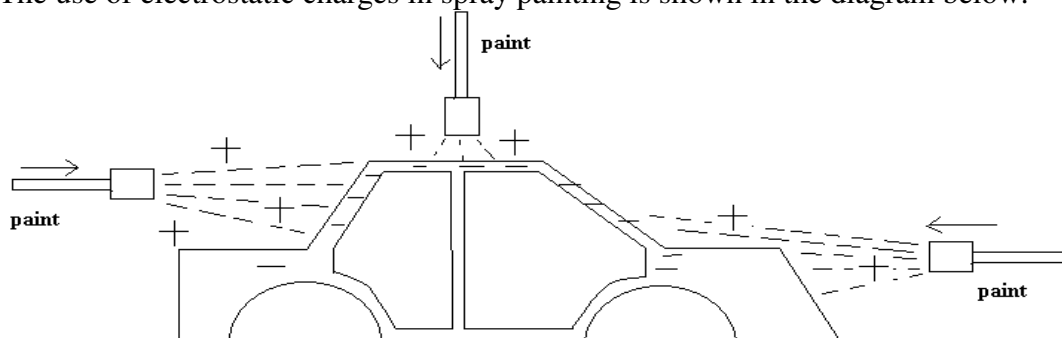

The spray of paint is given a positive charge (how?) and the car body a negative charge (how?).

As the droplets of paint come out of the nozzle of the spray gun, they lose electrons and become _____ charged. They then repel each other and form a fine mist. Just driving a car in air causes it to lose electrons by friction giving it a negative charge. The paint sticks to it in a fine even layer.

Question: Explain why it is an advantage to give:

[a] A charge of the same sign to all the paint droplets in the spray:

They repel each other to form a fine mist.

[b] The car body a charge of the opposite sign to that of the droplets.

The mist will stick to the car body.

Some people fit 'earthing straps' to the back of the car. The strap contains a metal band, which touches the road surface. Show how this strap discharges this positive charge on the diagram below. These are particularly important on petrol tankers. When transferring petrol from such a tanker, if so charged then sparks may jump from the equipment being used or the person igniting the petrol vapour. Charge (electrons) normally cannot either be removed or added to an oppositely charged vehicle because they cannot move / conduct through the rubber tyres (insulator).

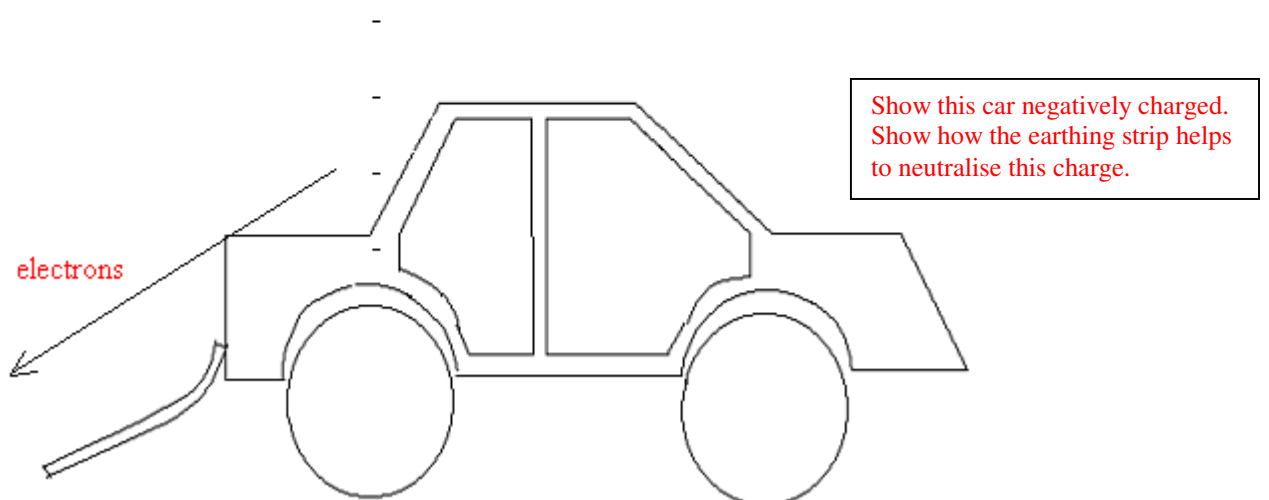
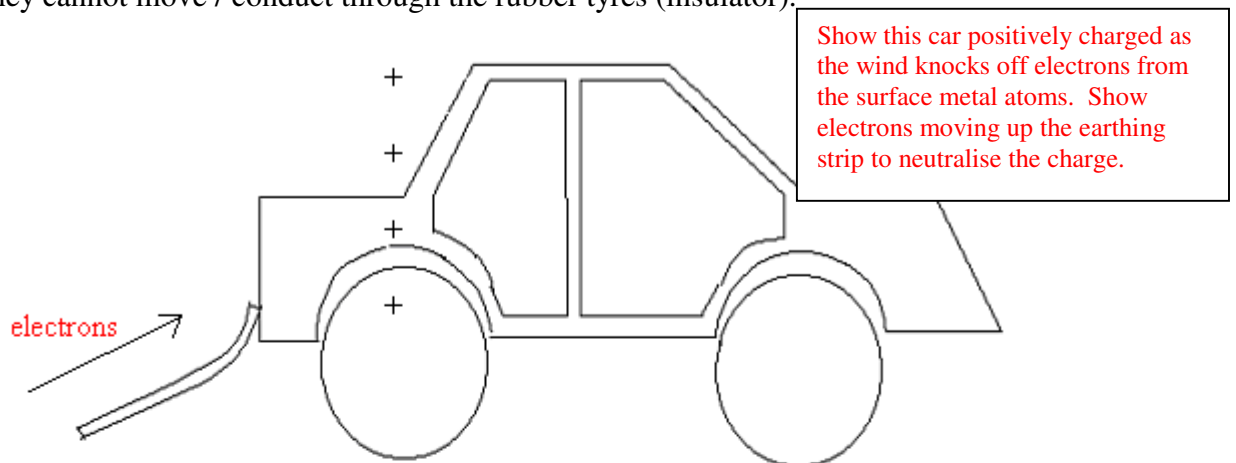

Sometimes when you are a passenger in a car – depending on the insulating clothes that you are wearing – you rub against the fabric of the seat. You then pick up a negative charge (electrons) which discharges when you touch the metal car.

This is a diagram of a Van de Graaff generator

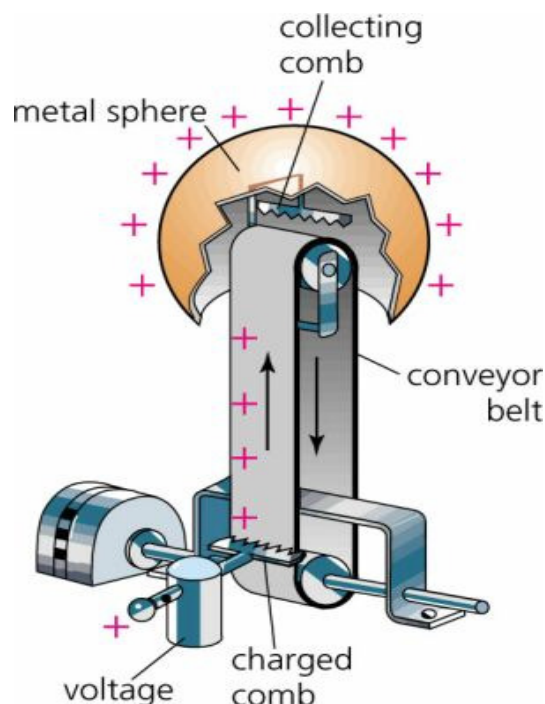

Question: Complete the text using the words that follow: **[Do this yourself]**

Inside the Van de Graaff generator, the moving belt is wound on a plastic pulley, When the motor drives the pulley, the belt rubs the plastic pulley. Air molecules around the belt lose _____ and become positively charged and attach onto the belt.

These positively charged air molecules are carried upwards into the metal dome by the _____ and fill it. The electrons [negatively charged] in the metal dome surface are attracted into the inside of the dome by these _____ air molecules. They are conducted into it through the attached metal comb.

This leaves a _____ charge on the surface of the dome.

Possible words: positive, negative, positive, negative, electrons, protons, friction.

The air (normally an insulator) becomes a conductor for a moment. There is a spark and the charge escapes to the earthed ball (or you if you get too close). Electrons can pass from your body if you stand on an insulator and hold the dome. This is seen as a spark. Electrons leave the hairs on your body leaving them all with a similar positive charge.

Question: Why should the hairs on your head stand on end when this happens?
All the electrons [negative] on your body [including your hair] are drawn onto the metal dome. Your hair becomes _____ charged and repels each other hairs, so it stands up.

Question: Complete the table [do this yourself]

| | | |
|---|---|---------|
| + | - | attract |
| + | | repel |
| - | | attract |
| - | | repel |

Question: A neutral carbon atom has six protons in its nucleus. How many electrons does it have? What happens to make it a positive ion?

Six electrons. If it loses electrons it will become a _____ ion.

Question: When a polythene rod is rubbed with a duster, it gains a negative charge. Why? What charge does the duster become? Explain why.

The polythene rod gains electrons and becomes _____ charged whilst the fur which has lost electrons become _____ charged.

Question: When an acetate rod is rubbed with a duster it becomes positively charged. Why? What charge does the duster become? Explain why.

The acetate rod loses electrons and becomes _____ charged whilst the duster which has gained electrons become _____ charged.

Question: What happens if a conductor becomes positively charged?

Attracts something which is _____ charged.

Question: Explain why when Gina pulls off her woolly hat very quickly her hair stands on end.

The hair loses electrons and becomes _____ charged. The hair then _____ each other.

Electric shocks

A person gets an electric shock if they become charged and then become earthed.

For example, a person can become charged if they walk on a nylon carpet or vinyl floor because:

- The floor is an insulator
- They become charged as they walk due to friction

The person can become earthed by touching water pipes or even another person.

Question: Jake got an electric shock when he touched the car door after a journey. How did the car become charged? As you sit in the car on the car seat you rub electrons off you and become _____ charged. Then when you touch the metal car, electrons move from the _____ into your finger producing a spark.

Question: Why can a person become earthed by touching water pipes?

Electrons come off your body and go down the pipe to Earth.

When static electricity is dangerous

Question: Complete the following text using the words that follow: [Do this yourself]

Static electricity is dangerous in conditions where there are explosive materials.

When inflammable gases or _____ are present or there is a high concentration of _____, a spark from static electricity could ignite the gases or vapours and cause an _____.

- When clearing oil tankers their _____ are first filled with an inert gas such as _____ to avoid a spark that would cause an explosion.
- Mobile telephones must not be used on petrol station forecourts to prevent _____ that could cause an explosion.

If a person touches something at a high _____, large amounts of electric charge may flow through their body to earth.

Current is the rate of flow of _____. The table shows that even small currents can be fatal.

| Electric current in mA (contact time is one second) | Effect on the body |
|---|--|
| 1 | Tingling sensation |
| 10-20 | 'Can not let go' muscles keep contracting |
| 100-300 | Ventricular fibrillation (heart attack), fatal in some cases |

The voltage that produces a particular current depends on the _____. The resistance of the body varies.

If a person is barefoot and sweaty, resistance is low and the _____ is greater for a given voltage.

Possible words: vapours, tanks, voltage, sparks, nitrogen, explosion, oxygen, charge, current, resistance

When static electricity is a nuisance

There are times when static electricity is a nuisance but not dangerous.

- Dust and dirt are attracted to insulators, such as a television screen.
- Clothes made from synthetic materials often 'cling' to each other and to the body.

Question: Why are high oxygen dangerous in a situation where electric charges are allowed to build up?

Should one insulator rub against another as electrons are transferred, this could create _____, which could ignite into flames in the high oxygen environment.

Question: Explain why clothes made from synthetic materials may cling.

Synthetic materials are insulators, which can become charged up negative or _____

Question: Explain why aircraft tyres are made from a type of rubber that conducts electricity.

Should the air craft get charged up as it passes through the air, then sparks would ignite and cause an explosion with kerosene fuel fumes when it is being put into the _____ every time it is refuelled.

Uses of electrostatics

Static electricity can be a nuisance but it can be a potential benefit to us all

- (1) A defibrillator delivers a controlled electric shock through a patient's chest to restart their heart.
- (2) A paint sprayer charges paint droplets to give an even coverage
- (3) A photocopier and laser printer use charged particles to produce an image.
- (4) Charged plates inside factory chimneys are used to remove dust particles from smoke.

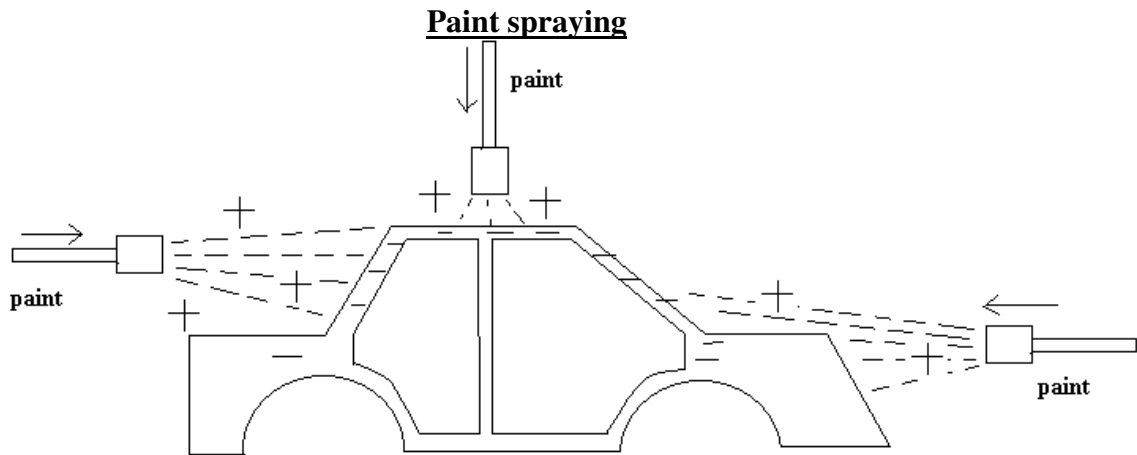

Question; Number the following statements in order, which shows the principle of paint spraying:

- The spray gun is charged [Do this yourself]
- All the paint particles are charged similarly positively (lose electrons), and they spread out, repelled by each other's similar charge as they are sprayed onto the car (produces a fine spray).
- Opposite charges attract and the paint is attracted to the object and sticks to it.
- The object to be painted is given the opposite charge to the paint (negatively charged electrons).
- To prevent this an uncharged object must be earthed. This would help the car to draw negatively charged electrons onto it to dispel the positive charge and allow the paint to stick.
- If the car is not given an opposite charge, the positively charge paint droplets will stick to it.

- Then more paint spray particles will be repelled away from the car.
- However, when painting small objects, they don't tend to be deliberately charged and therefore need to be earthed. However, with objects on the production line of a factory and in a vehicle repair shop, electrostatic paint sprayers depend on the fact that the object is charged with the opposite charge to the paint and therefore not earthed.

Electrostatic dust precipitators

Burning fuel, such as coal, pollutes the atmosphere not only with waste gases but also with smoke. Smoke consists of tiny particles of solid material. The smoke can be removed from the waste gases before they pass into the atmosphere by using a smoke precipitator

Many chimney gases carry large quantities of dust. Electrostatic precipitators can remove much of this dust. The diagram below shows the construction of such a precipitator. Label this diagram 1 to 7 corresponding to the following statements.

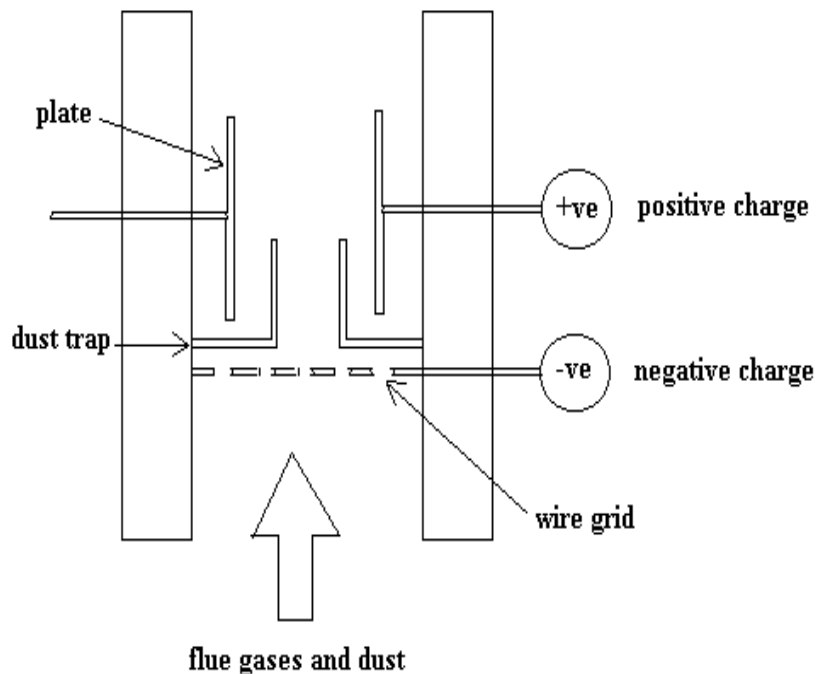

- (1) The waste gases pass by a charged metal grid; **[Do this yourself]**
- (2) The smoke particles pick up an electrical charge as they pass through the grid (negatively charged electrons);
- (3) The smoke particles are repelled by the similar charge on the grid;
- (4) The large collecting plates in the precipitator are given an opposite charge to that on the grid i.e. positive;
- (5) The smoke particles are attracted to the oppositely charged plates and stick to them (hence they are precipitated):
- (6) The collecting plates are knocked regularly so the smoke particles fall down and can be removed;

The waste gases are then free of smoke particles.

Question: A similar method to a dust precipitator is used for fingerprinting. Paper is put near a charged wire. A black powder is used in place of smoke. Suggest how it works.

The black powder particles are given one type of charge picked up from the wire sticks to the paper, which has a _____ charge.

Question: Write down two possible consequences of not using electrostatic dust precipitators in an industrial area with lots of chimneys.

Higher levels of particulates in the air, which could cause breathing problems such as _____ are produced.

Question: When disinfectant is sprayed on an area, the droplets of disinfectant are sometimes given a positive charge by a spray gun. Suggest why this is done. [Do this yourself]

Electric current

People use electrical appliances, from computers to washing machines every day. Electricity is safe if used correctly.

A modern domestic wiring system that includes fuses and circuit breakers is designed to protect people and property if an electrical fault occurs.

In the U.K, more than 28 000 fires a year are caused by electrical faults, leading to over 25 00 deaths or serious injury.

Circuits in series involving ammeters and voltmeters

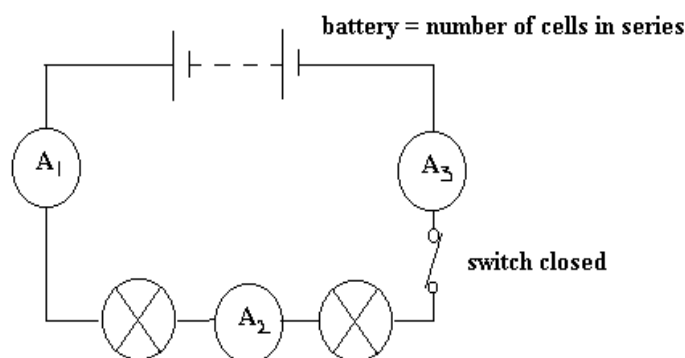

These bulbs are connected in series and the ammeter is placed in three different positions A1, A2 and A3 (1 amp flows when 1 Coulomb of charge passes per second).

Let A1 = 2 amps, so A2 = _____ and A3 = _____. [same]

This shows that when components are connected in series, the same current flows through each component.

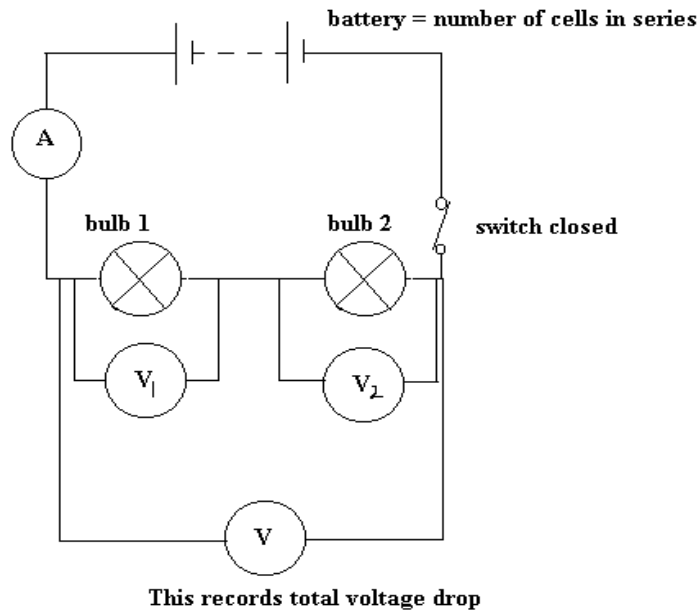

$$V_{\text{total}} = V_1 + V_2$$

1 Volt = 1 joule of energy per Coulomb of charge

A Coulomb = charge carried by a large number of electrons

If the voltmeter reads 3.4 volts (potential difference = 3.4 volts), this means that for every Coulomb of charge passing through the bulbs, then 3.4 joules of energy is changed to heat and light.

Now the more bulbs there are connected in series, the dimmer they will appear and the fewer amps (fewer number of electrons will pass through the bulb each second) will be recorded. This is because each bulb contains a small piece of resistance wire which tries to prevent electrons / electricity flowing through it. As a result, the greater the resistance, the smaller the current that will be recorded. We can measure the resistance of a wire from the following equation;

$$\text{Resistance } (\Omega \text{ called ohms}) = \frac{\text{potential difference (volts used up)}}{\text{Current (ampere, A)}}$$

This is called Ohm's law.

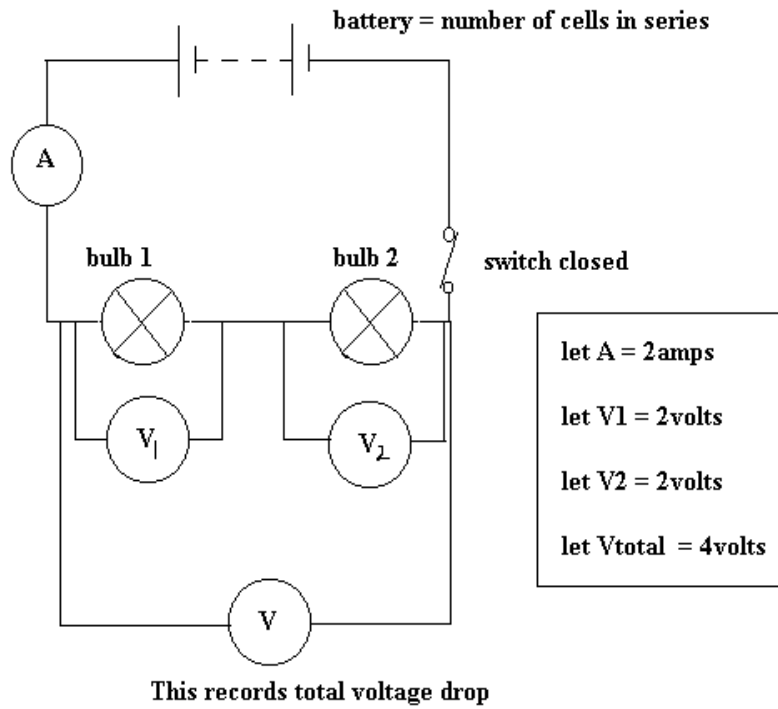

Now resistance of bulb 1 = r_1

$r_1 = 2\text{volts} / 2\text{amps} = 1\Omega$ Therefore the resistance of bulb 2 = r_2

$r_2 = \underline{\hspace{2cm}}$

Resistance of both bulbs in series (R)

$R = V_{\text{total}} / \text{amps} = \underline{\hspace{2cm}}$ Hence because $2 = 1 + 1$, then $R = r_1 + r_2$

This means that when components are connected in series, their total resistance is the sum of their separate resistances.

Remember: Resistance (ohms) = $\frac{\text{Potential difference (Volts)}}{\text{Current (Amps)}}$

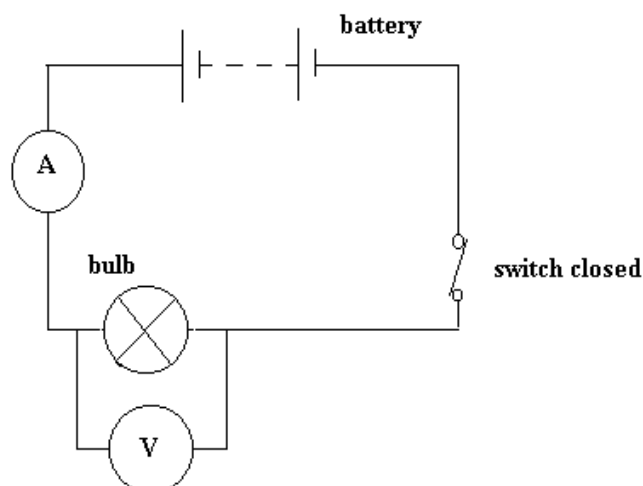
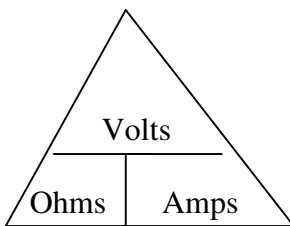

Question: The potential difference (volts) across the bulb is 4 volts and the current equals 2 amps. What is the resistance of the bulb?

Resistance [ohms] = Voltage [Volts] / Current [Amps] = _____

Question: The potential difference across the bulb is 6 volts and the bulb has a resistance of 2Ω . What is the current passing through the bulb?

Current [Amps] = Voltage [Volts] / Resistance [ohms] = _____

Question: The bulb has a resistance of 6Ω and the current equals 3 amps. What is the potential difference across the bulb?

Voltage [Volts] = Resistance [ohms] x Current [Amps] = _____

Question: 2 bulbs are connected in series, each with a resistance = 2Ω . The total potential difference across both bulbs = 4volts. What is the current passing around the circuit?

Voltage [Volts] = Resistance [ohms] x Current [Amps] = _____

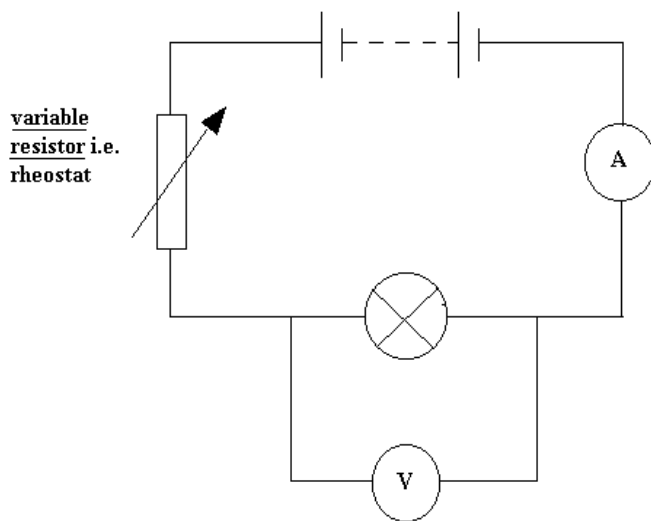

The circuit diagram shows a rheostat. This is a conductor whose resistance can be varied. It is a variable resistor. A slider moves along a coiled resistance wire. This increases or decreases the resistance in the circuit allowing more or less current through the bulb

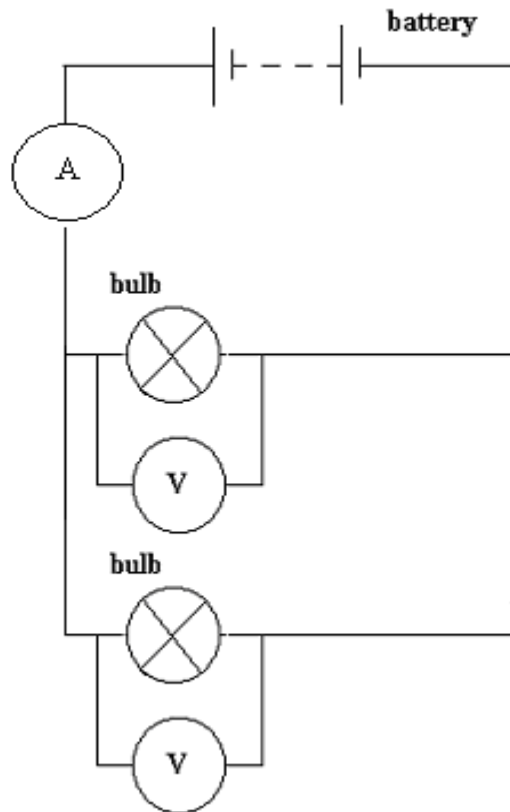

Question: In the above parallel circuit, the ammeter reads 4 Amps and each bulb has equal resistance.

[a] What is the current flowing through each bulb?

Remember, the current around a series circuit is the same all around it.

[b] Because the bulbs have an equal resistance, the potential difference [voltage drop] across them is the same. In this case it is 10 Volts. What is the resistance of each bulb?

Resistance [ohms] = Voltage [Volts] / Amps = _____

[c] Notice how the voltage drop across bulbs connected in parallel is the same. We can therefore say that if another bulb was connected in parallel, the voltage drop across this third bulb would equal _____ volts.

Current in a circuit

The current in a circuit must not be allowed to get too high.

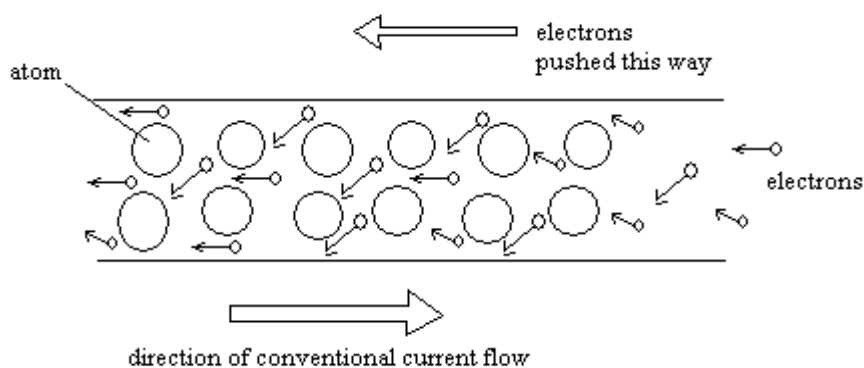

Electrons are 'pushed' around a circuit by the battery. They bump into atoms in the resistor. This makes the atoms vibrate more so the resistor gets hot.

The increased atomic vibrations impede the electrons' motion more so the resistance increases. The filament in a lamp connected in a circuit becomes so hot it emits light. We can then plot a graph of voltage against current and a graph similar to that shown at the top of the page will be produced. As more electricity is allowed to pass through the bulb, eventually the effect of electrons colliding into the atoms in the wire filament causes it to heat up. These wire atoms vibrate more producing a greater resistance to the current.

Question: Plot a line graph showing voltage (V) against current (A) for the bulb in the last circuit for the following results. Then plot a graph showing voltage (V) against resistance (Ω).

- (a) Show on both graphs where ohms law is being obeyed
- (b) Show when the temperature of the bulb filament is increasing and so in turn increasing the resistance of the bulb filament.

| Voltage (V) | Current (amps) | Resistance (ohms) |
|-------------|----------------|-------------------|
| 0.2 | 0.02 | |
| 0.4 | 0.04 | |
| 0.6 | 0.06 | |
| 0.8 | 0.08 | |
| 1.0 | 0.10 | |
| 1.2 | 0.12 | |
| 1.4 | 0.14 | |
| 1.6 | 0.15 | |
| 1.8 | 0.16 | |
| 2.0 | 0.17 | |

As indicated by the graph the bulb filament can get very hot at high voltages. The circuit we have described is similar to that shown in many kitchens whereby the rheostat represents a dimmer switch connected to a kitchen light. However, if that bulb filament, if it gets too hot, could burn itself out with sudden voltage surges from the mains. As a result, a fuse wire (or trip switch) is incorporated into the circuit. This is a short piece of special resistance wire that burns melts at high voltages (and temperatures), so protecting components in the circuit.

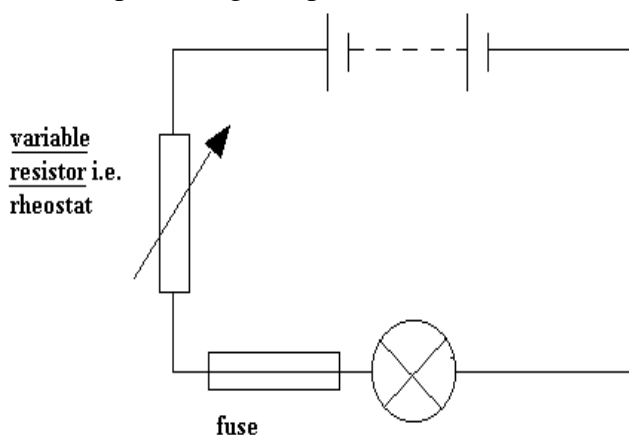

Question: Explain how a variable resistor acts as a dimmer switch varying the brightness of a lamp.

The dimmer switch contains a variable resistor, which changes the amount of _____ going to the bulb in the circuit.

Electrical Power

The electrical power of a power source [e.g. battery or cell] in a circuit is equal to the number of joules of electrical energy it transfers into that circuit every second.

Electrical power [Joules / second] can easily be calculated by multiplying Volts against Amps

$$\text{Volt} = \frac{\text{Joule}}{\text{Coulomb}}$$

$$\text{Amp} = \frac{\text{Coulomb}}{\text{Second}}$$

$$\text{Power} = \text{Volts} \times \text{Amps} = \frac{\text{Joule}}{\cancel{\text{Coulomb}}} \times \frac{\cancel{\text{Coulomb}}}{\text{Second}} = \frac{\text{Joule}}{\text{Second}}$$

Notice how Coulombs cancel out top and bottom to give Joules / second

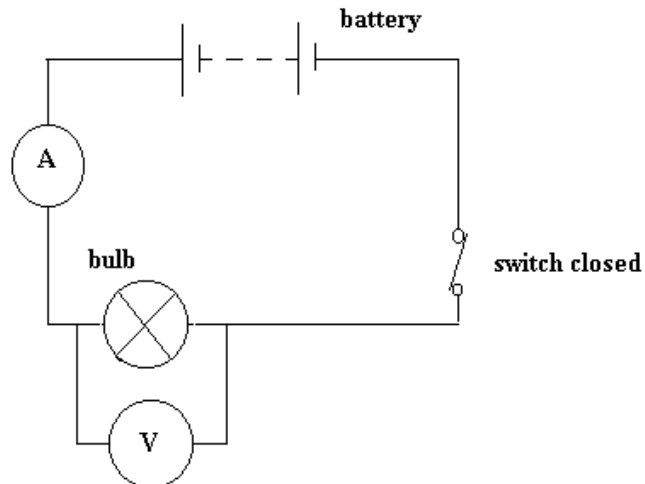

Question: The potential difference (volts) across the bulb is 4 volts and the current equals 2 amps. What is the power of the bulb?

Remember Power = Volts x amps

Understanding about the power of a bulb

The Power of a bulb is a measure of how many Joules per second of electrical energy is transferred / changed by an electrical device each second.

Example: A bulb changes 10 Joules of electrical energy into heat and light in 2 seconds. What is its power?

Answer: Power [Joules / second or Watts] = Total energy transferred / time taken = 10 / 2
= 5 Joules / second = 5 Watts

In electrical circuits, there is another equation that enables us to work out the power of a bulb:

$$\text{Power} = \text{Volts} \times \text{Amps}$$

Why is it when you have a parallel circuit, you can add more bulbs but they will always be the same brightness?

Yes, this is true. When we make the circuit each time the bulbs are just as bright as before.

This must mean that the power of each bulb must stay the same!

Can we explain this?

lets use ohm's law:

$$\text{Resistance [R]} = \frac{\text{Voltage [V]}}{\text{Current [A]}}$$

Therefore

$$\text{Current [A]} = \frac{\text{Voltage [V]}}{\text{Resistance [A]}}$$

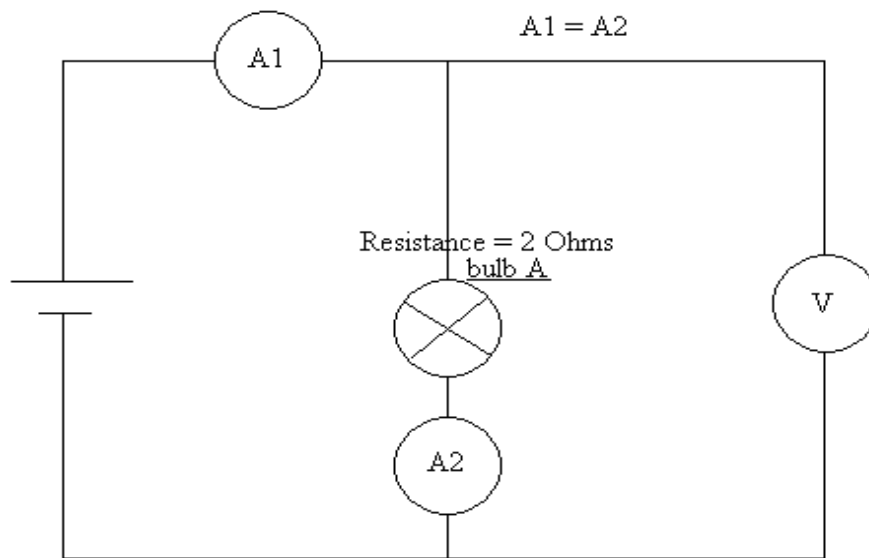

Now lets consider the first ammeter $A1 = 2$ Amps. All the components are connected in series so $A2 = 2$ Amps.

$$\text{Also Current} = \frac{\text{Voltage across bulb A [potential difference]}}{\text{Resistance of bulb A [2 ohm]}}$$

[2 Amps]

$$\text{So } 2 = \text{Volts} / 2$$

$$\text{Therefore Voltage} = 4 \text{ Volts}$$

$$\underline{\text{Power of bulb}} = \text{Volts} \times \text{Amps} = 4 \text{ Volts} \times 2 \text{ Amps} = 8 \text{ Watts}$$

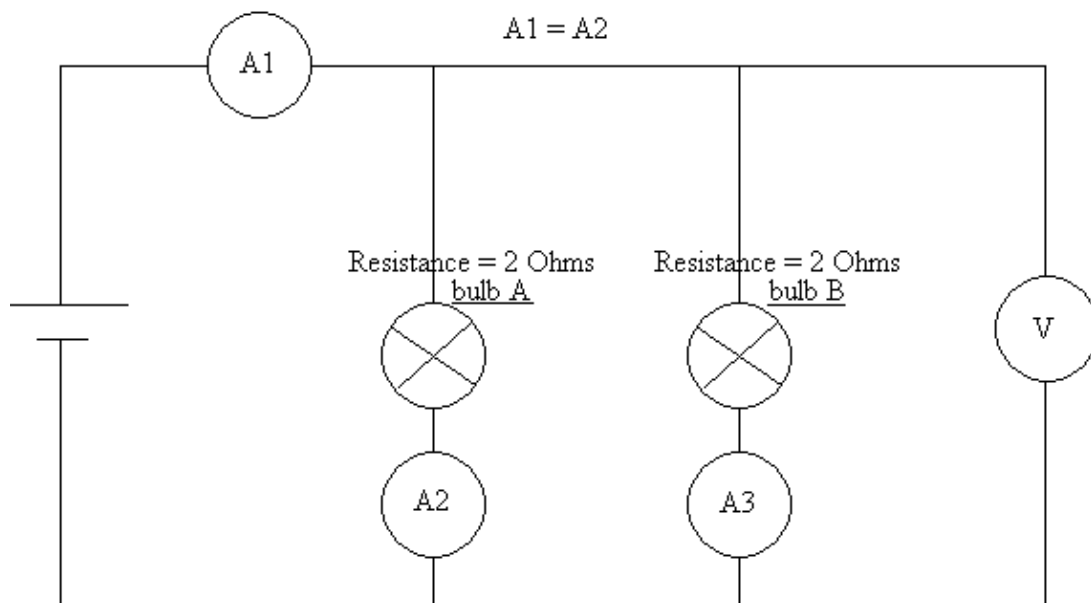

Now lets add another bulb of equal resistance to bulb B in parallel.

By doing this the overall resistance of the circuit actually decreases!!!!

Electrons find it twice as easy to pass through A1 round the circuit to the cell and then back to A1. Instead of having one single route through A2, they have another through A3. It is like another road being opened up to a flow of traffic [electrons]. This extra path means that the electrons move twice as fast as before around the circuit and so the current through A1 now changes from 2 Amps to 4 amps.

Now $A1 = A2 + A3$ and so $A2 = 2$ Amps.

As before $\text{Current} = \text{Voltage} / \text{resistance}$ for bulb A

Putting in the new numbers $2 \text{ Amps} = \text{Voltage} / 2 \text{ ohms}$. So the Voltage = 4 Volts

Now $\text{Power} = \text{Volts} \times \text{Amps} = 4 \text{ Volts} \times 2 \text{ Amps} = 8 \text{ watts}$

This is exactly the same power for this bulb as before and so it is the same brightness.

The potential divider circuit

Some circuits use two fixed resistors in series with a supply voltage (V_s) between their ends

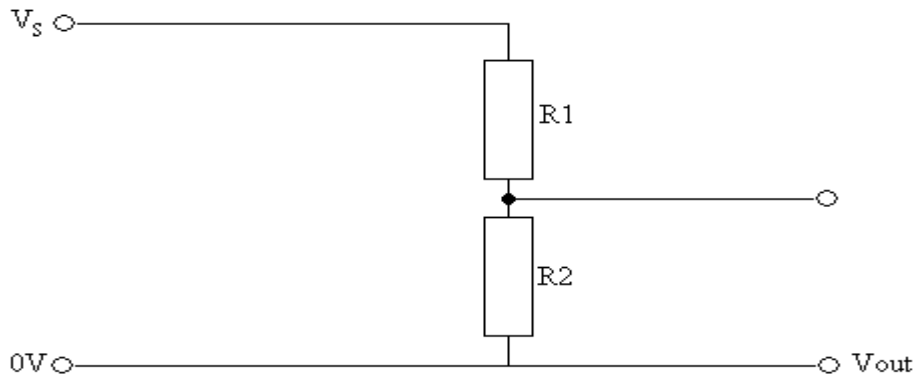

Potential divider circuit with two fixed resistors in series

The potential difference between the ends of each resistor is proportional to its resistance because they both have the same current.

The output potential difference is between the ends of one of the fixed resistors.

Question:

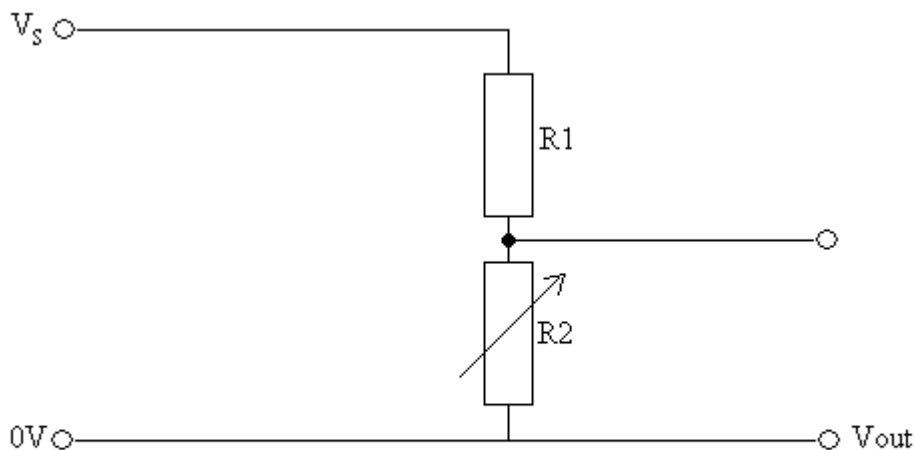

Potential divider circuit with a variable resistor

If one of the resistors is a variable resistor, the output potential difference can be altered.

Question: What happens if we increase the resistance of the rheostat R_2 ?

Electrons move from V_s through the resistor R_1 to the top of R_2 and then have difficulty pass through this resistor and pass out the circuit to the right. There are more electrons carrying energy to the top of R_2 than below it. This means that the voltage across this resistor R_2 must _____ [big output voltage V_{out}].

Question: What happens if we decrease the resistance of the rheostat R_2 ?

Electrons move from V_s through the resistor R_1 to the top of R_2 and then have no difficulty passing through this resistor. There as many electrons carrying energy to the top of R_2 than below it. This means that the voltage across this resistor R_2 must be _____ .

Light-dependent resistors

Light-dependent resistors, decrease their resistance when light shines on them. Thermistors (thermal resistors), decrease their resistance when it gets warmer.

From Computer Desktop Encyclopedia
Reproduced with permission.
© 2007 PerkinElmer

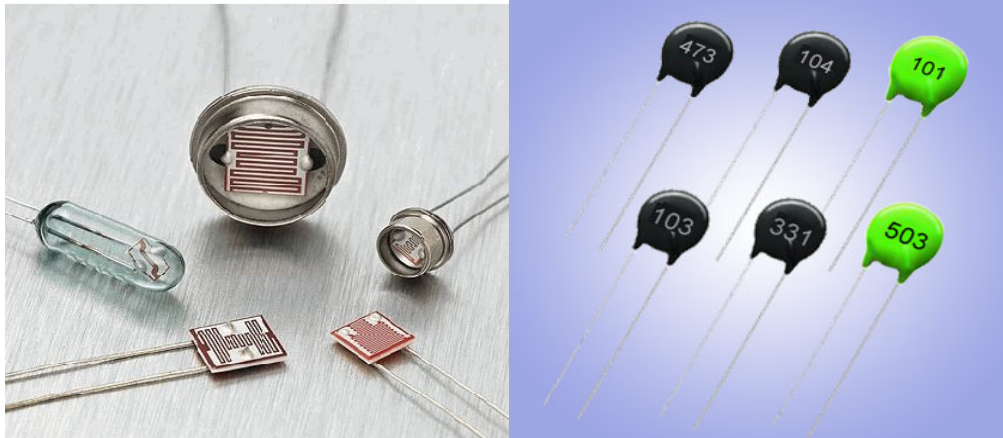

Light-dependent resistors

Thermistors

Question: How does light intensity affect the properties of light-dependent resistors?
The electrons in atoms in the LDR absorb light energy. They become so excited that they are lost from these atoms and pass away from it through the wire. This means that the _____ of a LDR decreases.

Light dependent resistor (LDR) characteristics

- The resistance of a light dependent resistor decreases as light level increases.
- Its resistance is about $100\ \Omega$ in bright sunlight but it can be over $10\text{M}\Omega$ in the dark.

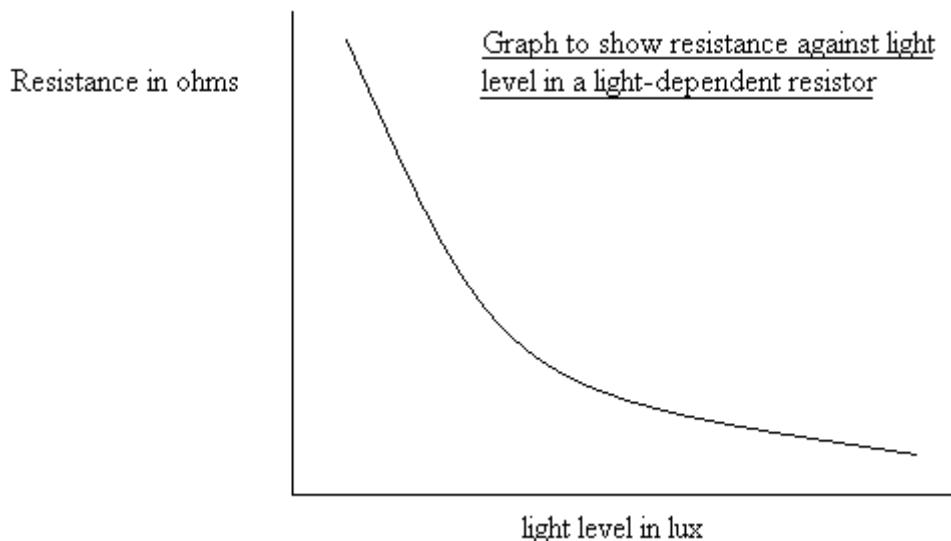

Thermistor characteristics

- The resistor of a thermistor decreases as the temperature increases.
- Each thermistor has its own characteristics but a typical relationship between resistance and temperature is shown below:

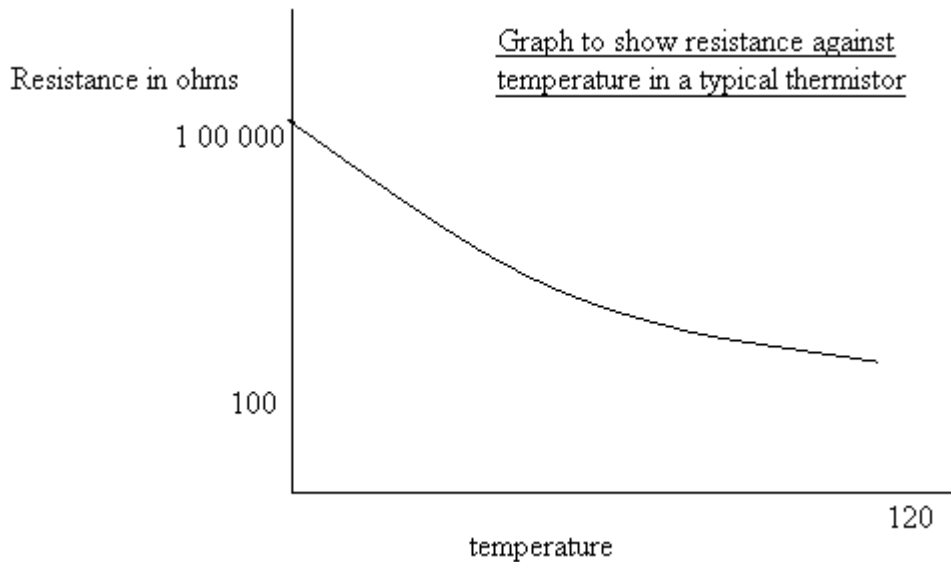

Question: The resistance of a light-dependent resistor (LDR) is measured as 150Ω .

Suggest where the LDR might be situated.

It could be part of a umpire's light meter or maybe a light detector connected to an outside lighting system.

Question: Look at the previous graph showing resistance readings taken with a thermistor. Does the resistance of the thermistor ever fall to zero?

Useful potential divider circuits

Question: Complete the text using the words that follow: **[Do this yourself]**

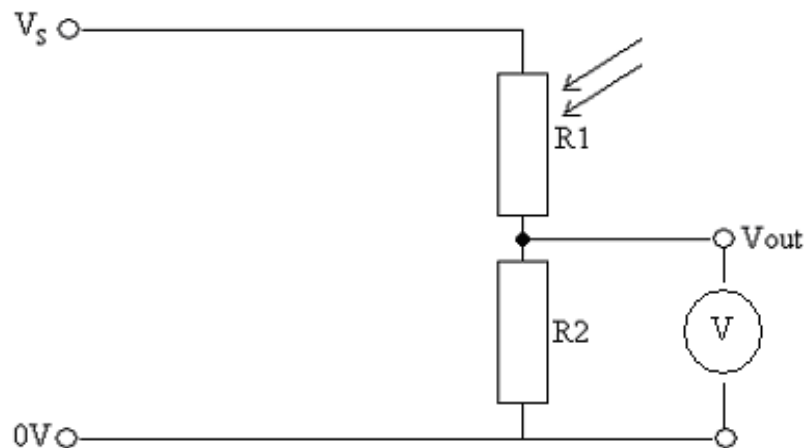

Circuit used in streetlights

If light shines on resistor R1 [Light dependent resistor [LDR]] its resistance _____ and electrons flow to the top end of the fixed resistor R2. This _____ the potential difference [voltage] across the fixed resistor R2, as measured by the _____. The voltmeter reading gives a simple indication of the light intensity. This circuit makes a useful _____ meter.

If the positions of the LDR and the fixed resistor are reversed, the output potential difference decreases, as it gets darker.

Possible words: decreases, increases, light, voltmeter

Temperature control

A thermistor (R_2) can also be used in a potential divider circuit. When the temperature falls, the output potential difference rises and can be used to switch on a heater.

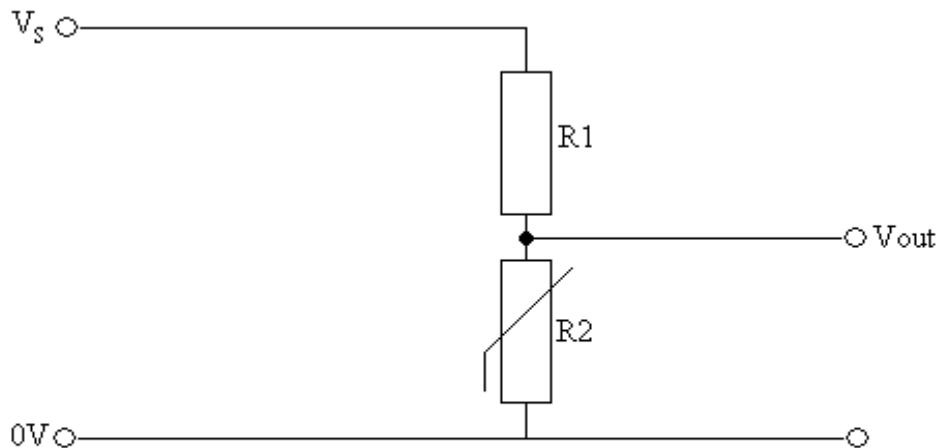

Potential divider circuit with a thermistor

The resistance of a thermistor decreases as the temperature increases. This is the opposite behaviour to a resistor.

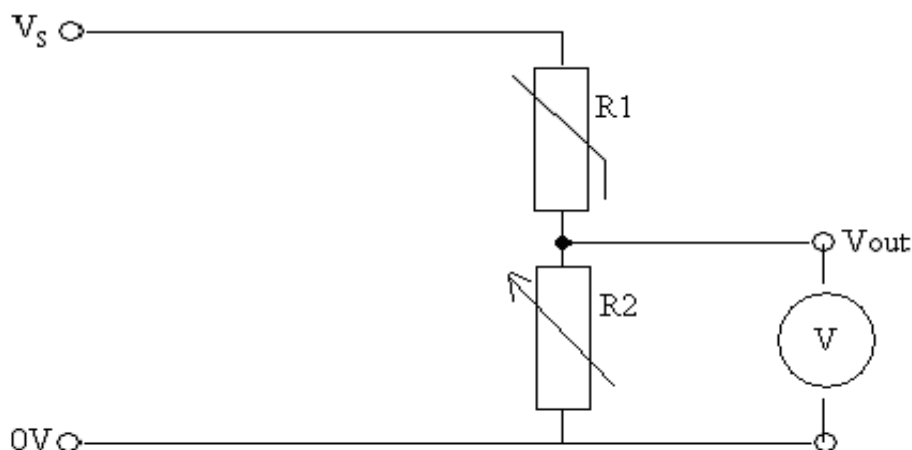

Potential divider circuit with a thermistor

Question: Explain how the potential divider circuit with the thermistor can be used to measure the temperature of the room. [The variable resistor / rheostat, can be used to set the temperature range that the circuit measures – include to mention how it does this].

Electrons move from V_s to the resistor R_1 . If it gets warm, its resistance _____. The electrons then move through this to the top of R_2 . We can set the resistance of the Rheostat to whatever we want [sets the temperature range that we want to detect]. These electrons then pass out of the circuit. Depending on the resistance of R_1 depends on how many electrons pass out of the circuit to perhaps a motor which opens a window to let cool a room. The colder R_1 , the fewer electrons pass through it and the fewer _____ pass to the motor.

How a fuse works

A fuse in a plug or in a main fuse box contains a length of wire that must be replaced after a fault has occurred and been connected.

The length of wire melts if the current becomes too large. This breaks the circuit. Fuses of values 5A and 13A are commonly available for use in a three-pin plug.

Fuse ratings

A fuse can have a rating of 3, 5 or 13 amps. This means that they will allow a current to pass through them to the live wire, up to the specified rating, but above this they will burn out. Electrical appliances have components, some of which may be more susceptible to current overload than others. This makes the selection of the correct fuse in a plug so very important. It must have a value higher than but as close to, the current through the appliance when it is working normally.

The current drawn by a device is related to the power of that device.

To answer the following questions, you will need to use the equation:

| |
|---|
| $\text{Power} = \text{voltage} \times \text{current}$ |
|---|

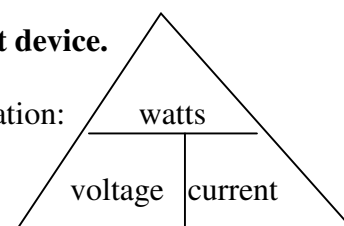

In all the following questions, assume that mains electricity = 230 volts

(1) A television has a power of 2 kilowatts. What would the best fuse rating be for its plug? [2 kilowatts = 2000 watts]

Current = 2000 watts / _____ Volts = _____. Then choose the current rating.

(2) A fish tank heater has a power rating of 100 watts. What would be the best fuse rating for its plug?

Current = 100 watts / _____ Volts = _____. Then choose the current rating.

(3) A cooker draws a current of 10 amps

(a) What is its power?

(b) How many coulombs of charge will it transfer in 10 seconds?

(c) What fuse would be appropriate for its plug?

Power [watts] = Volts x Amps = 230 Volts x 10 amps = _____ Watts

Current [Amps] = Coulombs of charge / time [seconds]

Therefore Coulombs charge = Current x time = _____

Then choose the correct fuse rating.

Generating electricity

A bicycle dynamo is a small electrical generator.

A magnet rotates inside a coil of wire and an alternating current is produced. If we have a **magnetic field** and a wire is made to **move** in / cut that field, we can induce a **current** in that wire.

When the magnet is moved in and out of the coil of wire, an a.c is induced in the wire

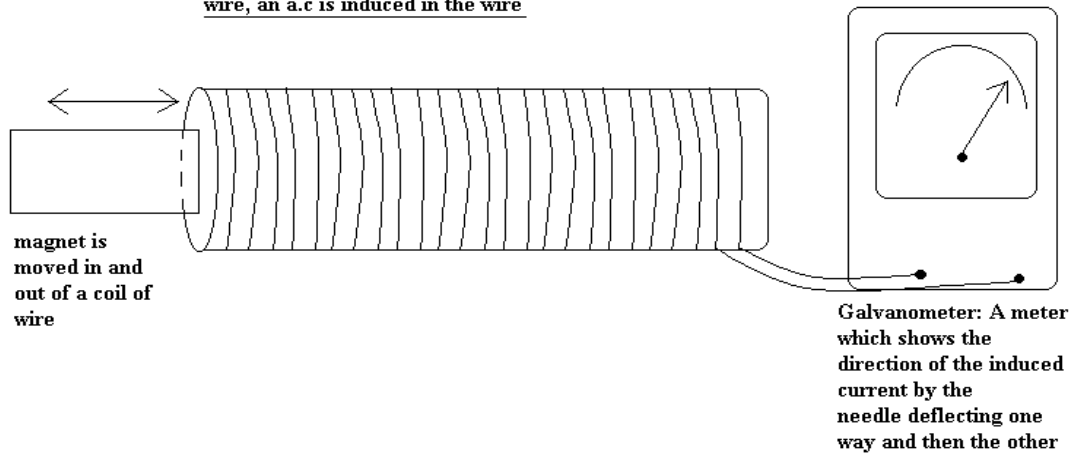

Question: Would a current be induced if the magnet remained stationary inside the coil of wire? Explain as fully as possible.

[Remember you need a magnetic field moving across a wire to pull electrons off the wire atoms and make them conduct through the coil of wire]

Question: How could the size of the induced A.C be increased?

The faster the magnet moves in and out of the coil of _____ and the more turns of wire in the coil.

Question: What is the difference between a current from a battery and a current from a dynamo?

The current from a battery is a direct current from negative to the _____ side of the circuit. The current from a dynamo [small electrical generator that you would find on the wheels of a bike] is an Alternating _____.

Electricity can also be generated, not just by moving a magnetic field in and out of a coil of wire (or even rotating / spinning a magnet in a coil of wire) but also by rotating a coil of wire in a magnetic field. A generator can be made by any of these methods.

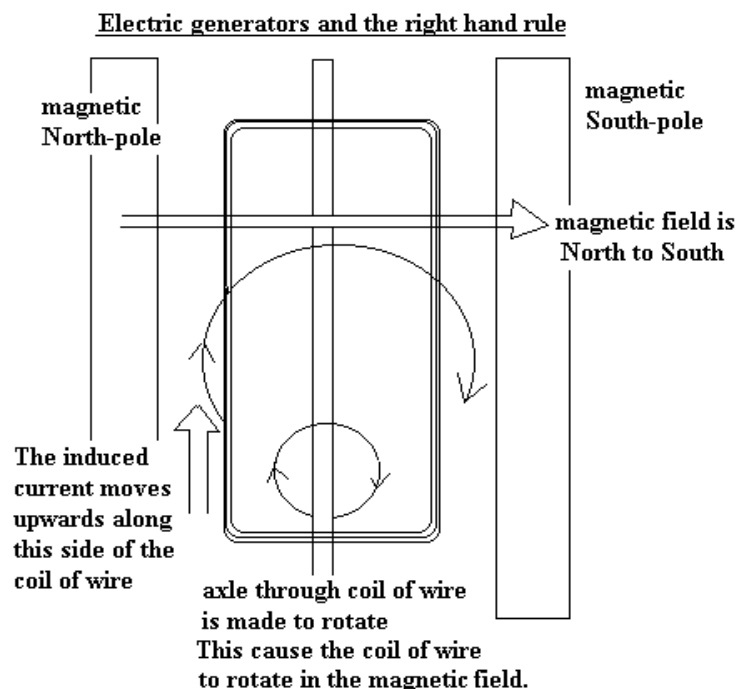

In a dynamo on a bicycle, a rotating magnet inside a coil of wire produces a moving magnetic field, which is continually cutting the wire so inducing a current.

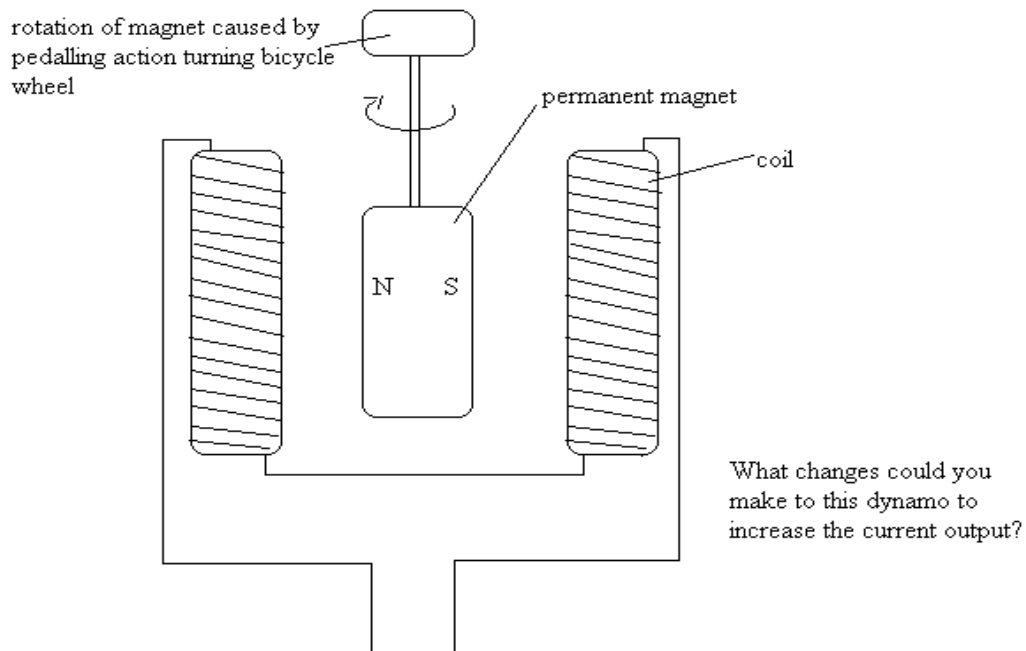

There are three methods to increase the current from a dynamo:

- Use a stronger magnet
- Increase the number of turns of wire on the coil
- Rotate the magnet faster on a bicycle-this means pedalling faster.

The dynamo produces a changing voltage and current. An oscilloscope shows how the alternating voltage changes with time. The maximum voltage and the frequency can be found from the trace.

However, as we know, the mains supply is a.c. This means that for a fraction of a second, the live wire experiences an increasing positive voltage (increasing amount of energy given to current, pushing it into the appliance). This then starts to decrease after a maximum voltage is reached (rise and fall after peak on oscilloscope trace). The live wire then starts to give the current a negative voltage (pushing it in the opposite direction, increasing to a peak and then decreasing again. This is shown by a trough on the oscilloscope trace.

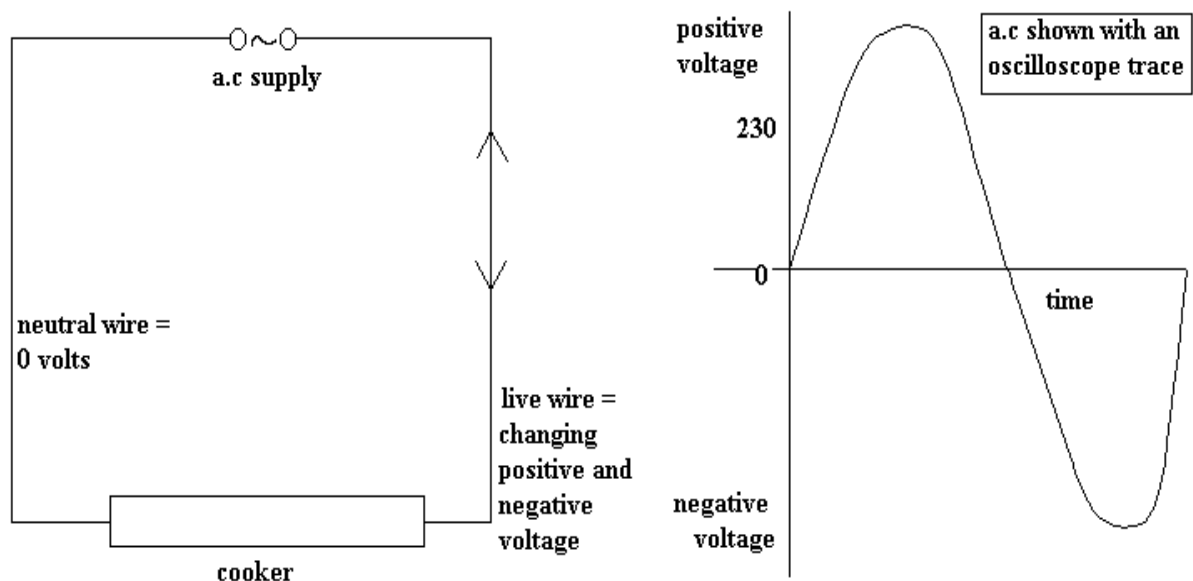

Question: The height of the wave is the maximum (peak) voltage. The length of the wave shows the time for one cycle called the period. Show these on the oscilloscope trace below.

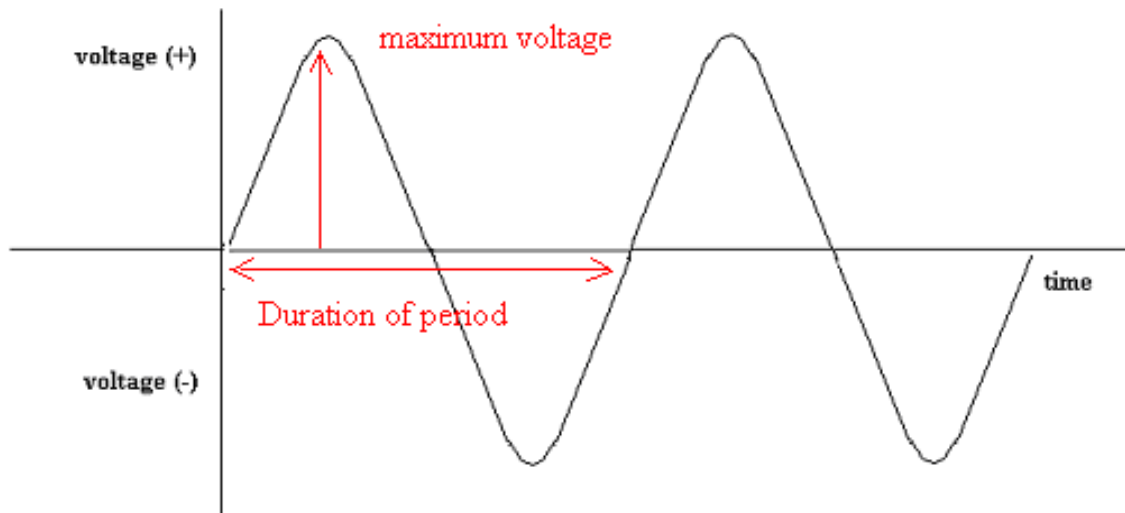

To calculate the frequency, the following equation is used:

Frequency = 1 / period

The National Grid distributes electricity around the United Kingdom at voltages as high as 400 000V. This high voltage leads to:

- Reduced energy loss
- Reduced distribution costs
- Cheaper electricity for consumers

Transformers in the National Grid step down (reduce) or step up (increase) the voltage.

Transformers and the National Grid

A power station generates electricity at 25 000V.

Transformers increase or decrease the input voltage of the a.c. that they receive. They are made by putting two coils of wire around a soft iron core as shown below:

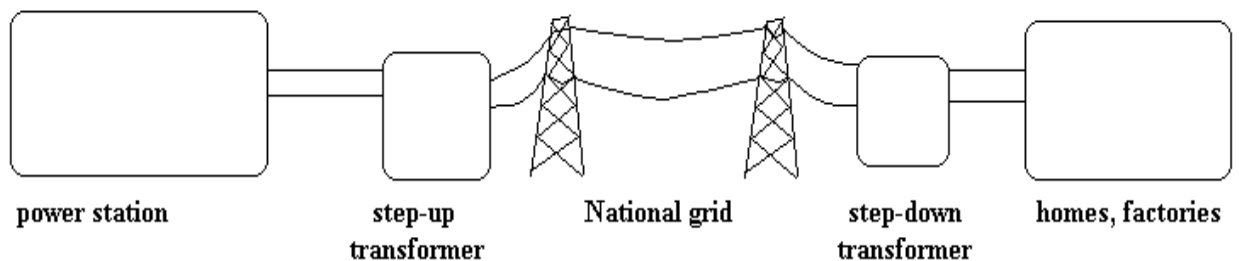

In this step up transformer, the voltage of the input current entering the primary coil is increased in the output current of the secondary coil

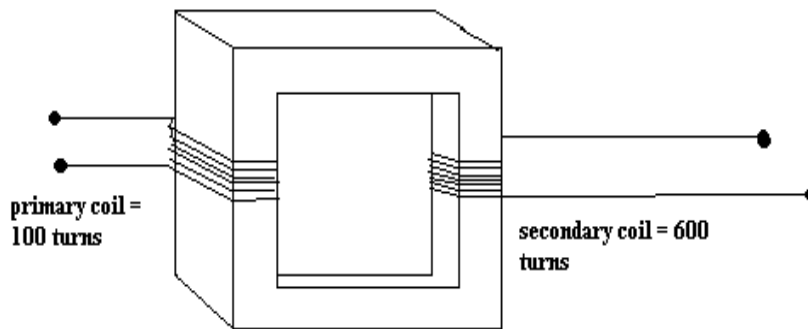

Question: Complete the following text regarding transformers using the words that follow: **[Do this yourself]**

Alternating current from the power station generator passes to and fro through the primary _____ of the step up transformer. Now this produces two out of the three requirements previously considered i.e. a continually **moving magnetic field** around a secondary coil of _____. As a consequence, an alternating current is induced in the _____ coil of wire the transformer.

If the secondary coil has more turns of wire than the primary coil, then this is called a step ____ transformer and the induced voltage is _____ than the input voltage.

If the secondary coil has fewer turns of wire than the primary coil, then this is called a step _____ transformer and the induced voltage is _____ than the input voltage.

Possible words: up, down, higher, lower, wire, secondary, coil.

Homes, shops and offices use 230V, but large factories may receive 33 000V whilst small factories, hospitals and schools receive 11 000V.

There will be an electricity substation (step down transformer) near where you live. This is a dangerous place. Even if you do not touch the wires or terminals, electricity can jump through the air and pass through your body causing severe burns or deaths. This reduces the voltage from 11 000V to 230V.

Question: An isolated farm has its own transformer. It is mounted at the top of a tall pole in the farmyard. What type of transformer is it? Explain.

Step down transformer delivering electricity from the National grid.

Why is it necessary to increase the voltage of alternating current before it can be transmitted along the National Grid?

The higher the voltage, the smaller the current needed to transmit energy at the same rate. If there are fewer amps being transmitted along the wire, even though those electrons are carrying more energy (more volts), then there will be fewer collisions of electrons into wire atoms each second and so less energy will be wasted heating up the power lines. This makes sense because we have already stated that:

Power of primary coil turning electrical energy into moving electromagnetic energy = Power of secondary coil turning moving magnetic energy back into electrical energy

| |
|---|
| <p>Volts (primary coil) × Amps (primary coil)</p> <p>= Volts (secondary coil) × Amps (secondary coil)</p> |
|---|

Question: The electricity produced by a power station and entering the primary coil of a transformer is at 15 000volts and 500 amps. The secondary induced voltage = 150 000volts. Show that there is a decrease in the current induced in the secondary coil.

Remember Amps (secondary coil)
= Volts (primary coil) × Amps (primary coil) / Volts (secondary coil)

The voltages across the primary and secondary coils of a transformer are related as shown:

$$\frac{\text{Voltage across primary (volt, V)}}{\text{Voltage across secondary (volt, V)}} = \frac{\text{Number of turns on primary}}{\text{Number of turns on secondary}}$$

Question: Complete the following table. Use the space provided underneath the table to help you with your calculations. **[I have given you three examples to get you started]**

| Volts in primary coil | Volts in secondary coil | Number of turns in primary coil | Number of turns in secondary coil |
|-----------------------|-------------------------|---------------------------------|-----------------------------------|
| 1000 | 10000 | 30 | (a) |
| 250 | [25 x 5000]/250 | 25 | 5000 |
| 200 | 1000 | 250 | [1000 x 250]/200 |
| 1000 | 2000 | 300 | [2000 x 300]/1000 |
| 3000 | 60 | (e) | 500 |
| 300 | (f) | 20000 | 2000 |
| 40 | 400 | (g) | 70 |
| 380 | 760 | 500 | (h) |

Question: A step-down transformer has 10 000 turns on its primary coil and 200 turns on its secondary coil. 500v are applied to the primary coil. What is the output voltage?

[500Volts x 200 turns] / 10 000 turns

Question: A transformer has the same number of turns on its primary coil as on its secondary coil. How does the secondary voltage compare to the primary voltage?

Secondary voltage = primary voltage

Induced voltage

The primary coil has an alternating current passing through it.

The alternating current produces an alternating (changing) magnetic field in the iron core.

Remember that a dynamo works because a changing magnetic field (caused by rotation) induces a changing voltage.

In a similar way, a transformer works because a changing magnetic field (caused by the changing current in the primary coil) induces a changing voltage in the secondary coil.

Transmission loss

Reducing transmission loss

Electrical power depends on voltage and current

Power = voltage x current

The electrical power supplied to the primary coil of a transformer depends on the input voltage and current.

$$P_p = V_p I_p$$

Similarly, the output power of the secondary coil is given by:

$$P_s = V_s I_s$$

Assuming the transformer is 100% efficient, no energy is lost to the surroundings.

$$P_p = P_s$$

$$V_p I_p = V_s I_s$$

- This means that if the voltage is increased by a step up transformer, the current is reduced by a reciprocal amount.
- Electricity is generated at 25kV and transmitted at 400kV. The voltage is increased by a factor of 16. The current in the secondary coil is only a 1/16 of the current in the primary coil.
- Since energy transfer depends on the square of the current, this means that power loss is reduced by a factor of 16 squared = x256.
- The power loss by transmitting electricity at 400kV is 1/256 of that which would be lost if the electricity were transmitted at 25kV.

Question: Chris has run a cable from his house to a store in a field 200m away. When he boils a 2kW kettle in the store, he finds it takes much longer than when he boils it in the house. It does not take any longer to boil the kettle in his house than it does at the power station 25 miles away.

Explain these observations.

The electricity transmitted from power station to home is at a high voltage and low current [400kV]. At this high voltage there is little power loss. Therefore you get the same amount electricity / second in the home as you would in the _____ station. However, if we now try to transmit this electricity from home to store in a field 200m away, we do so with a low voltage. When this occurs you get significant _____ loss.

Question: A primary coil of a transformer = 24kV and 5Amps. The secondary coil = 12kV. What is the current in the secondary coil?

Current in secondary coil [Amps] = $[24\text{kV} \times 5 \text{ Amps}] / 12 \text{ kV} = \underline{\hspace{2cm}}$

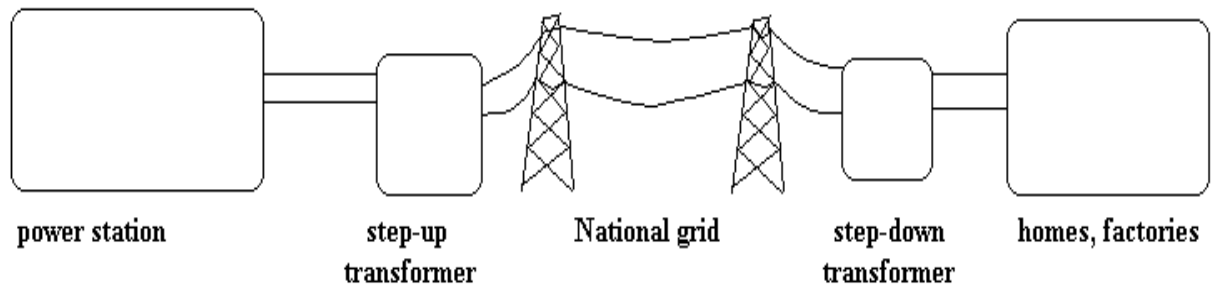

Question: What is the purpose of step up and step down transformers?

The step up transformer increases the voltage on the current coming out of a power station. This enables it to be transmitted along the National Grid with relatively small power loss. The step down _____ then reduces this voltage before it goes into our _____ to make it safe for us.

Question: Explain what a consumer of electricity means

Anyone who uses electricity generated in a _____ station.

Question: Explain how electricity is generated in a power station.

A moving magnetic field cuts across a coil of wire. This pulls electrons forwards and backwards through the coil of _____.

Question: Other than from the cooling towers, where is energy lost in a coal-fired power station?

Energy is lost by friction as the turbine turns and tries to spin the magnetic suspended within the coil of _____.

Question: What happens to the steam after it has turned a turbine in a power station?

The steam has lost some of its heat and kinetic energy after it has turned the _____. Therefore it is best to condense it back to liquid _____ and then reboil it to high pressurised and high temperature steam.

In this step up transformer, the voltage of the input current entering the primary coil is increased in the output current of the secondary coil

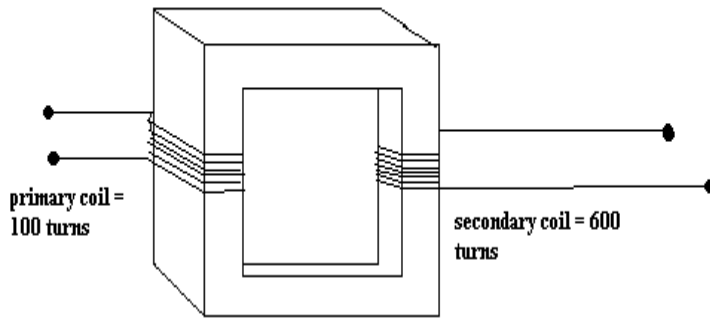

Question: Complete the following text regarding transformers using the words that follow: **[Do this yourself]**

Alternating current from the power station generator passes to and fro through the primary _____ of the step up transformer. Now this produces two out of the three requirements previously considered i.e. a continually **moving magnetic field** around a secondary coil of _____. As a consequence, an alternating current is induced in the _____ coil of wire the transformer.

If the secondary coil has more turns of wire than the primary coil, then this is called a step ____ transformer and the induced voltage is _____ than the input voltage.

If the secondary coil has fewer turns of wire than the primary coil, then this is called a step _____ transformer and the induced voltage is _____ than the input voltage.

Possible words: up, down, higher, lower, wire, secondary, coil.

The higher the voltage, the smaller the current needed to transmit energy at the same rate. If there are fewer amps being transmitted along the wire, even though those electrons are carrying more energy (more volts), then there will be fewer collisions of electrons into wire atoms each second and so less energy will be wasted heating up the power lines.

This makes sense because we have already stated that:

The number of joules energy transmitted / second (watts / power) = volts x amps

A current's field

When there is an electric current in a wire, the wire is surrounded by a **magnetic field**.

If the wire is in the north-south direction, the compass needle is parallel to the wire (A). When the current is switched on, the compass needle rotates until it is at right angles to the wire (B).

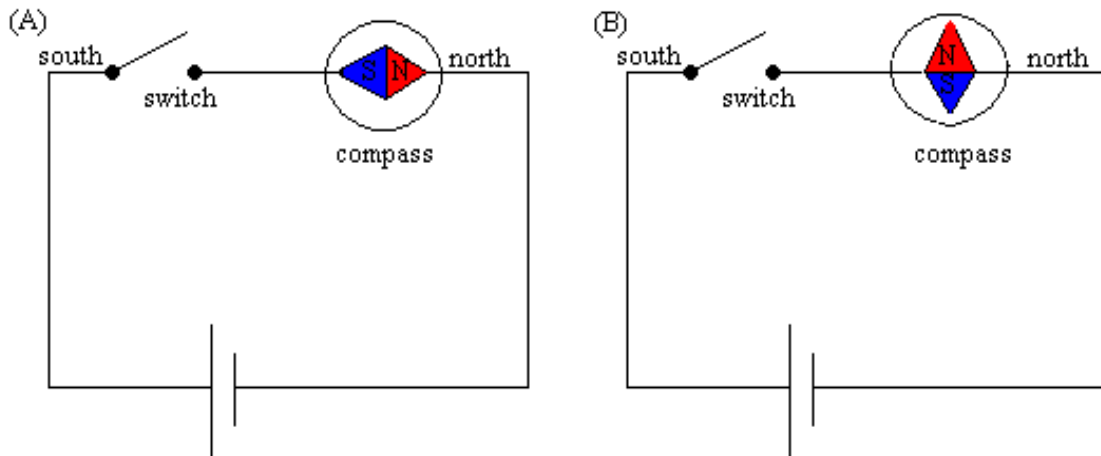

The magnetic field made by the current in a wire is a circular shape around the wire.

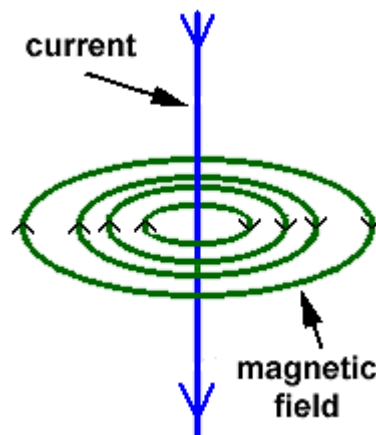

If a wire is in a magnetic field and the current is switched on, the two magnetic fields interact and the wire moves.

What happens when two North poles of a magnet are brought close together?

Question: Draw around this bar magnet its magnetic field.

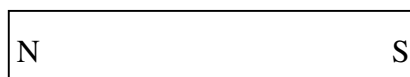

Motors at home

The electric motor has many uses around the home. These are examples of the devices they power:

- Car windscreen wipers
- Electric lawnmowers
- Kitchen blenders, whisks and food processors
- Electric drills, sanders and automatic screwdrivers

- Potable CD players and DVD players

Question: What type of energy transfer takes place when a motor is operating?

Electrical energy to _____ energy [remember it is spinning].

Question: Which of the five household appliances listed below have a motor in them?

Deep-fat fryer, fan, hairdryer, radio, smoke alarm, television, toaster, tumble dryer, video recorder, washing machine

Magnetism and electricity

Before we consider the relationship between magnetism and electricity, let us review what we learned at key stage 3 about magnets.

A magnet exerts a force on any piece of magnetic material including iron and steel, or another magnet, which is placed near it. (There is a magnetic field around the magnet.)

A coil of wire acts like a bar magnet when an electric current flows through it. One end becomes a north-seeking pole and the other end a south seeking pole. This is called an electromagnet.

Magnetic fields, current electricity and movement

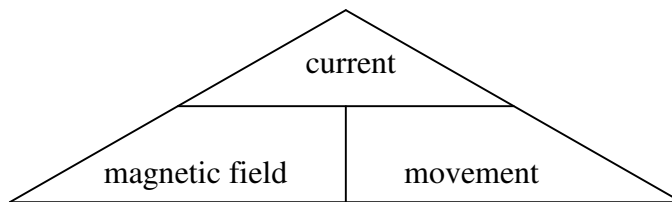

The triangle shows us an important relationship.

(a) A wire carrying a **current** in a **magnetic field** —————> the wire is made to **move = electric motor**

(b) A wire **moving** in a **magnetic field** —————> a **current** is induced in the wire = **electric generator**

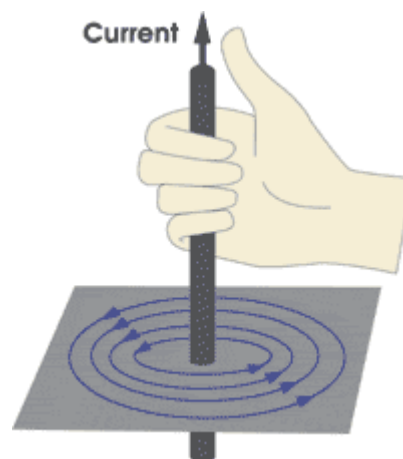

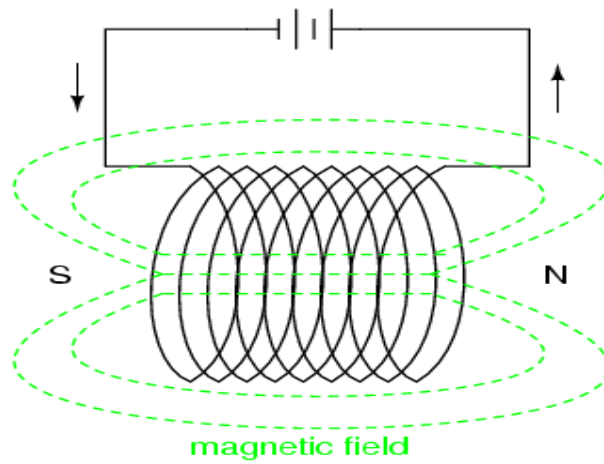

The right hand grip rule

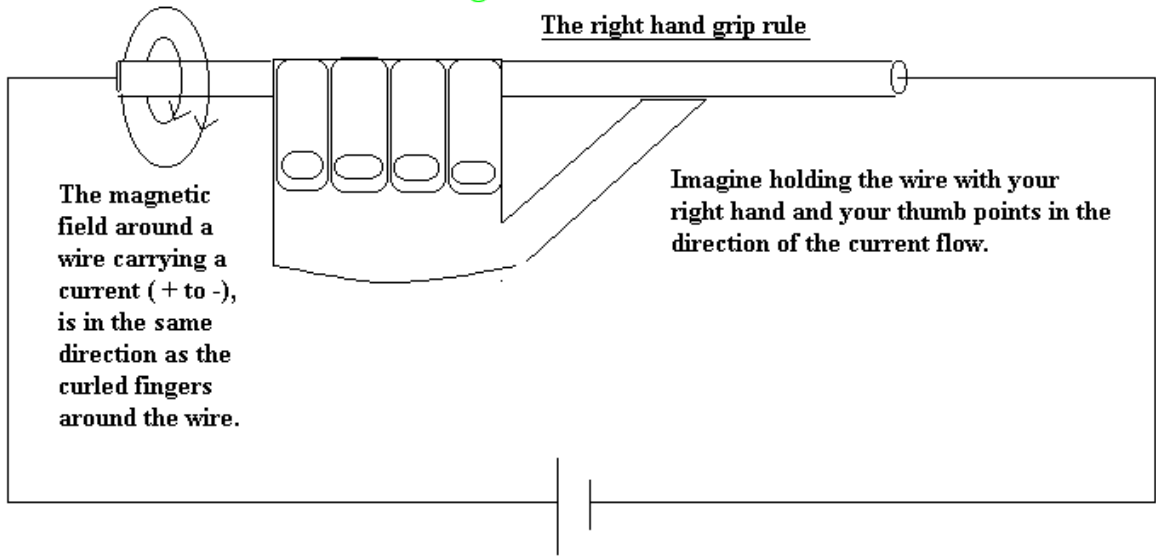

The magnetic field around a wire carrying a current (+ to -), is in the same direction as the curled fingers around the wire.

Imagine holding the wire with your right hand and your thumb points in the direction of the current flow.

Magnetic poles at the ends of coils of wires



Imagine that a coil of wire is wrapped around an iron core. If we look down one end and the conventional current flow is in the direction as shown, we can imagine drawing a N (for north pole end of the electromagnet) in that end with corresponding arrow directions.



Now imagine that we look down the other end. We can imagine drawing a S (for south pole of the magnet) in that end with corresponding arrow directions.

A long coil of wire is called a solenoid. The magnetic field due to a solenoid is similar to the field produced by a bar magnet.

Question: In what ways can an electromagnet be made stronger?
[Think number of turns of wire and voltage of the electricity]

Question: What happens if you reverse the direction of the current passing through the electromagnet?
The magnetic field [North to South] will change its _____. [Polarity changes].

Question: How would you show that the polarity of the electromagnet had changed?
The pointer dial of a plotting compass points towards the South pole of an electromagnet.

A current passing through a wire in a magnetic field produces a thrust force (electric current \longrightarrow kinetic – principle of electric motor)

From the diagram below it follows that when a wire carrying an electric current is placed in a magnetic field, it may experience a force pushing against it. In effect, the magnetic field is repelling the electromagnetic field around the current carrying wire. If the wire is wound around to make a coil through which is an axle, then that coil would spin around. This is the principle of the simple d.c electric motor.

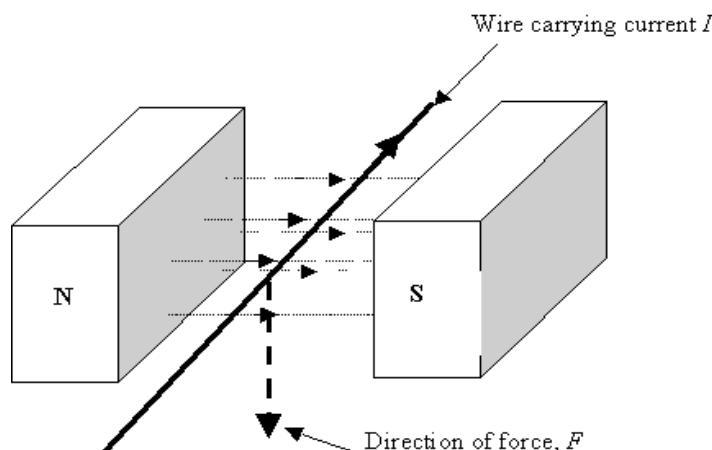

Electric motors and the left hand rule

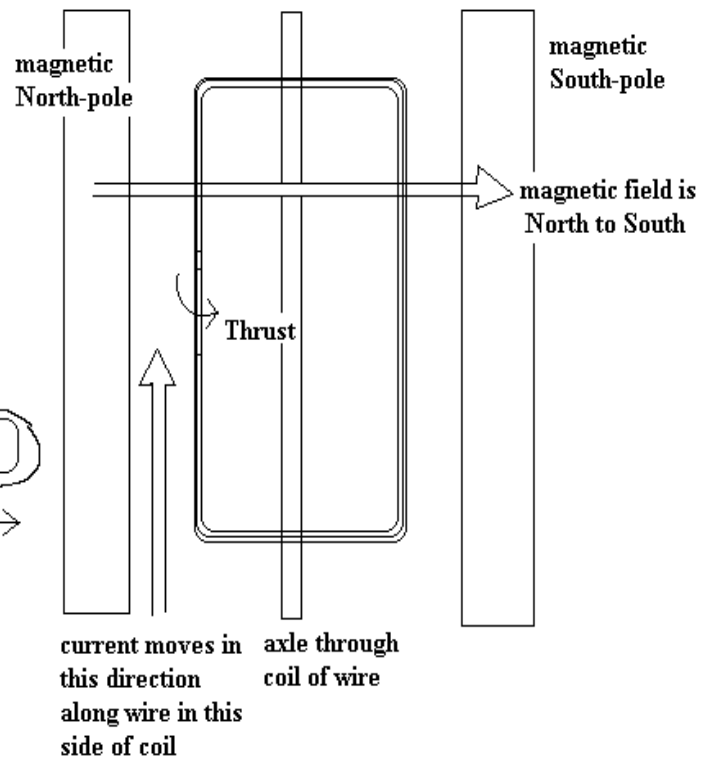
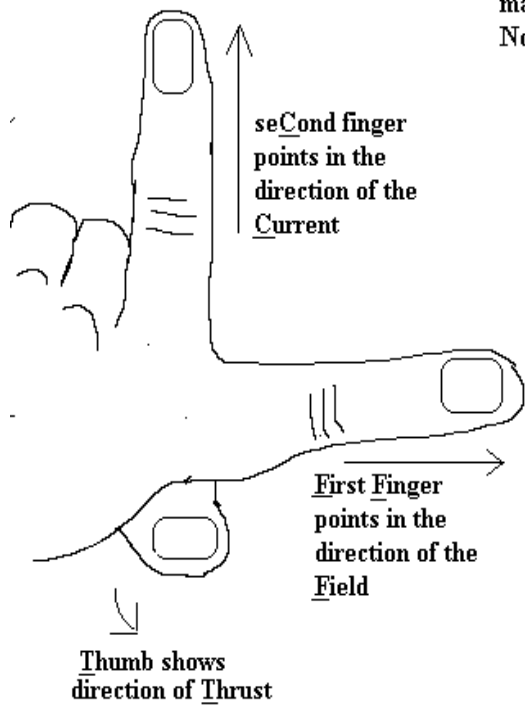

Question: Consider that the current moves in the direction shown on the diagram of the motor below. Show the direction of the thrust of magnetic repulsion [Bit difficult with a two dimensional drawing. Notice how the thumb [thrust] is pointing out of the paper towards the reader. This will act on the left hand side of the coil [coloured in red] as long as the current direction [second finger] is downwards.

Electric motors and the left hand rule

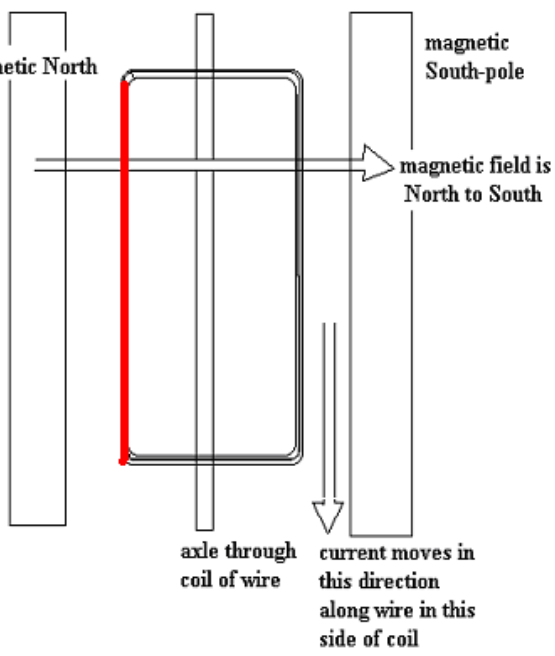
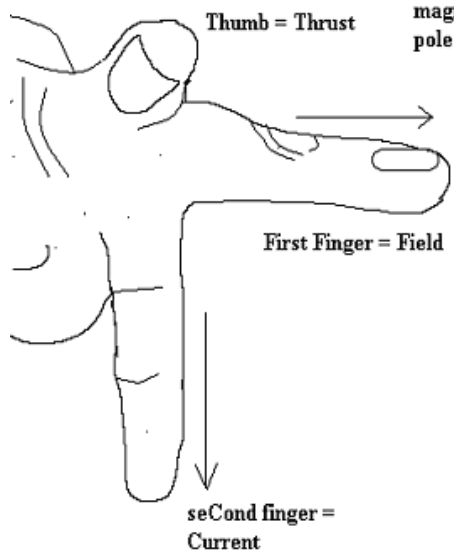

The size of the magnetic repulsion force making the coil spin around can be increased by:

- Increasing the strength of the magnetic field
- Increasing the size of the current

Question: Use your left hand to help you to label this diagram of an electric motor

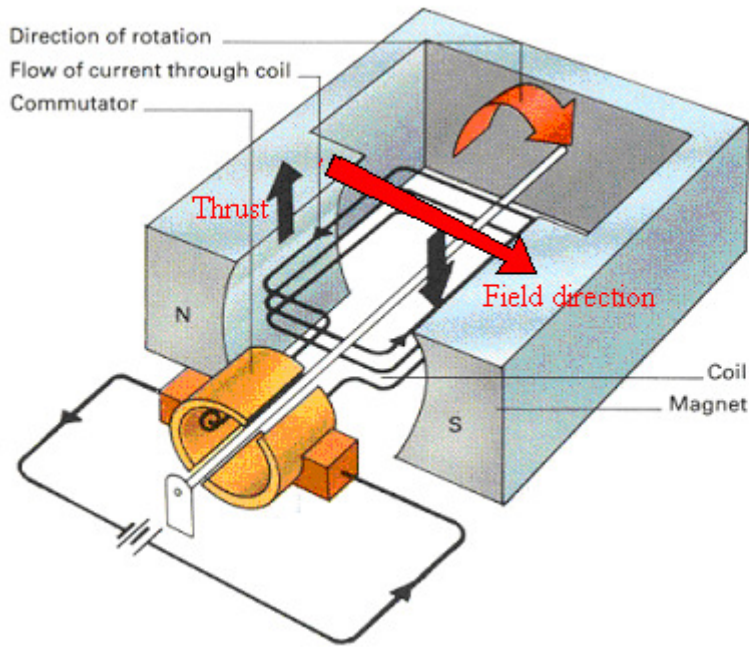

Question: What happens to the speed of rotation of a motor if the current is reduced?
 Reduces

Question: What happens to the direction of rotation of a motor if the current direction is reversed?
 The direction of _____ is reversed.

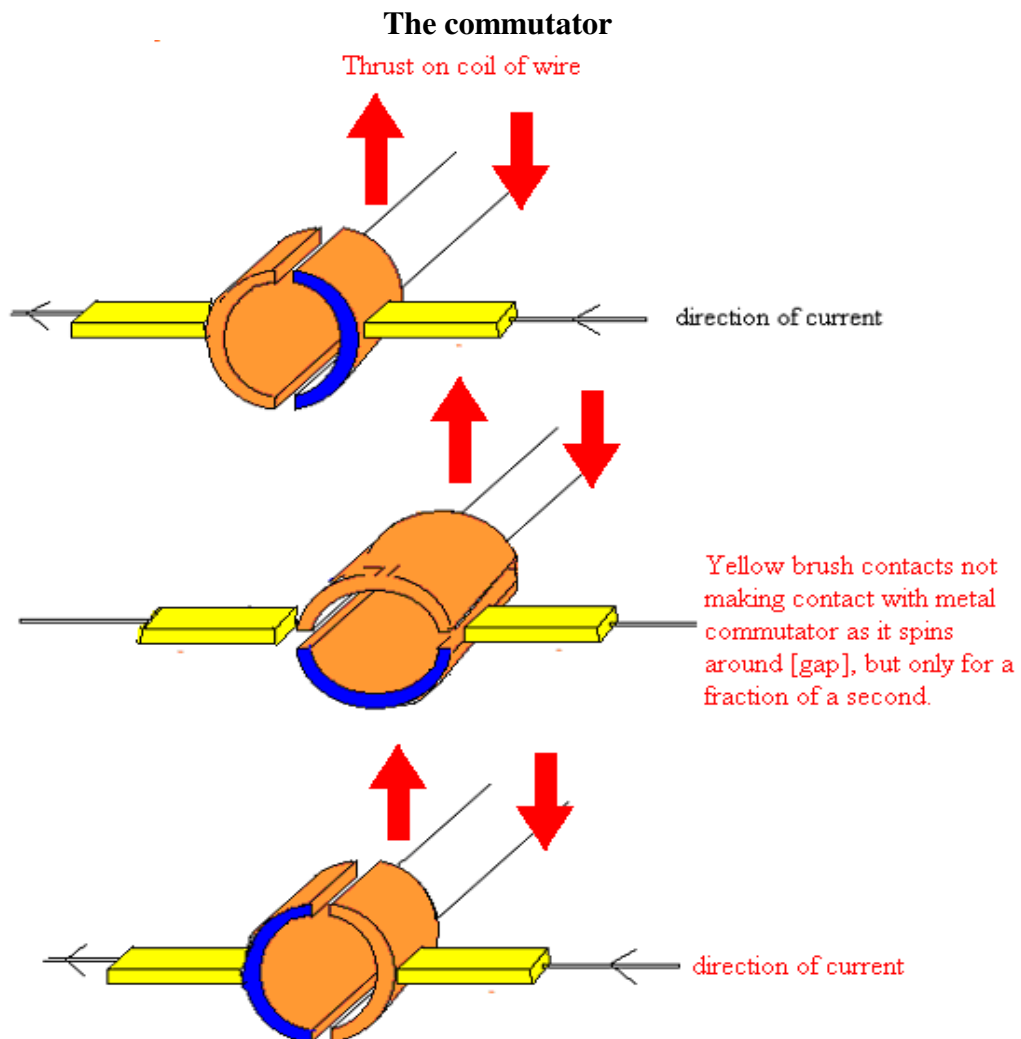

Question: A commutator makes a motor continue to spin. The brush contacts touch the split ring commutator as it spins in diagram 1 and 3 but not diagram 2.

- (a) Show the direction of the current in the wire in the coil in all three diagrams.
- (b) Use Fleming's left hand rule to show the direction of the force on the two wires of the coil shown in the diagrams.
- (c) Does the coil spin clockwise or anticlockwise? **[Work this out yourself]**

A radial field

Practical motors have pole pieces that are curved. This produces a radial field. The coil is always at right angles to the magnetic field. This increases the force and keeps it constant as the coil turns.

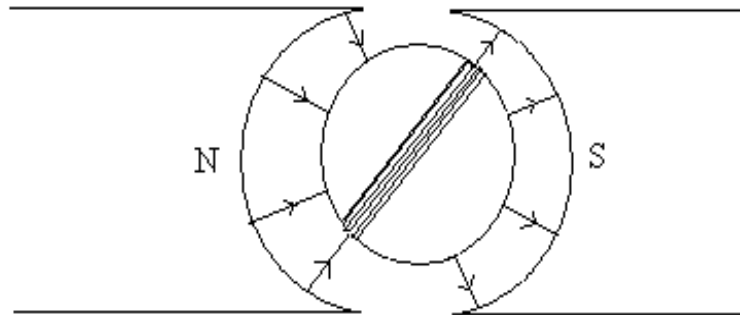

Label the coil of wire in this diagram

Question: What would happen to the coil of a motor if the coil were connected directly to a battery without a commutator?

It would not be possible to maintain a constant direct flow of current through the wire of the coil so the motor would not work.